

13/01/2017



USE AND MAINTENANCE HANDBOOK

**PICK-UP BALER
M61 EXPORT/160
M61 EXPORT/170**

CE



SITREX S.p.A. – Agricultural Machinery
Zona Industriale – Viale Grecia, 22 – 06018
Trestina (PG) - Italy

CONTENTS

WARRANTY	4
INTRODUCTION	4
MARKING AND IDENTIFICATION	4
SAFETY	5
LIFTING THE MACHINE	8
START-UP.....	8
LUBRICATION AND MAINTENANCE	11
SAFETY DEVICES.....	13
JAMMING.....	15
PISTON PAWL.....	16
PHASE.....	17
BALE CHARACTERISTICS	20
ADJUSTMENTS.....	22
PICK-UP	23
TWINE BINDING DEVICE.....	24
IRON WIRE BINDING DEVICE.....	31
WHEEL MOUNTED BEHIND THE PICKUP.....	38
THIRD WHEEL.....	38
PICK-UP AND DRAWBAR HYDRAULIC CONTROL.....	39
CHARACTERISTICS	39
END OF SEASON STORAGE	40
PREPARATION FOR THE NEW SEASON.....	40

WARRANTY

The machine built by the company is guaranteed for 12 consecutive months from the date of purchase, provided that it is used according to the instructions contained in the Use and Maintenance manual and operates under normal working conditions. It is only under these conditions that the manufacturer agrees to supply spare parts, at no charge, for those components which, in the opinion of the manufacturer, have production or material defects; or, in its unquestionable opinion, to make repairs directly or by using authorized personnel.

The buyer will pay for any labor and transportation costs relative to this warranty.

The warranty expires if the equipment was used without complying with the instructions contained in the Use and Maintenance manual, or if it is was repaired, disassembled or modified by unauthorized workshops.

Spare parts replaced under the warranty must be returned to the manufacturer.

The warranty will not be valid for cases involving poor maintenance and abnormal use of the machine. Any disputes will be under the competence of the judicial authorities of Alessandria - Italy.

INTRODUCTION

Read this manual carefully before using the machine.

This handbook conforms with EEC Machine Directive 89/392 and subsequent amendments.

The manufacturer reserves the right to make changes, without prior notice and without any sanctions, without affecting the main technical and safety data.

The symbol  WARNING calls the reader's attention to indicate that non-compliance may lead to personal injuries or death of the operator.

This publication is divided into chapters which discuss the relative machine use and maintenance operations.

Please follow these instructions to ensure the best machine operating efficiency.

It is recommended to use only original spare parts (consult the Spare Parts catalogue).

- This manual indicates the standards that will guarantee regular machine maintenance and use, thus avoiding problems which might damage the machine and reduce its operating performance.
- Despite the fact that technical service is available at any time, the manufacturer is not responsible for any non-compliance with the standards contained in this handbook.
- This machine was built for operations only for the agricultural sector and therefore the owner will be personally responsible for any improper use of the picker baler. Any other use is considered to be improper.
- In case of breakdowns, the machine must be repaired by skilled personnel under safety conditions in compliance with the accident-prevention standards and rules regarding technical safety, road traffic and job health.
- When the machine is delivered, check that the equipment has not been damaged during transportation and that accessories (if any) are complete. Claims will only be accepted in writing within eight days from the date of delivery.

MARKING AND IDENTIFICATION

When the machine is received, check the marking on the cover of the equipment.

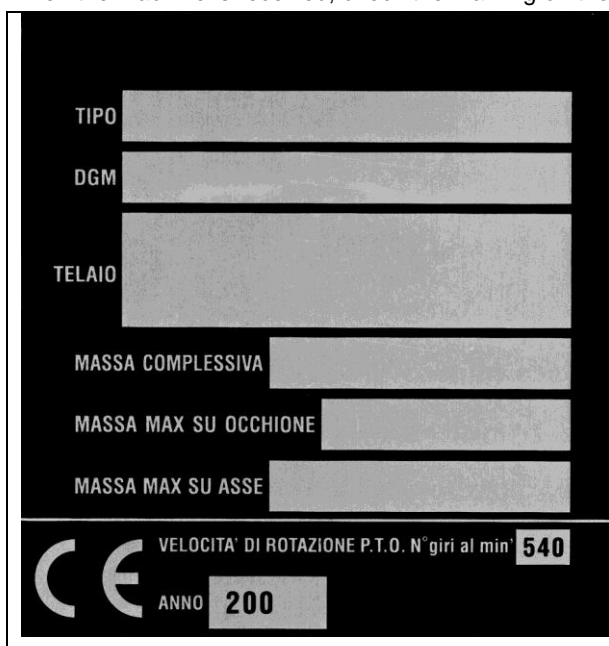







(EXAMPLE OF RATING PLATE)

Each machine is equipped with an EC rating plate and an EC declaration of conformity in accordance with EEC directive 89/392 and subsequent amendments.

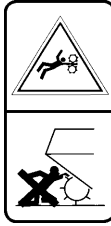
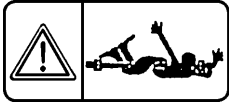
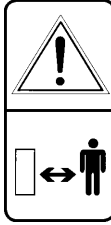
SAFETY

SAFETY LABELS

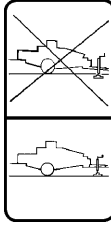
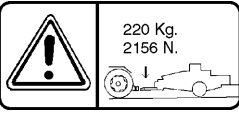
ENGLISH

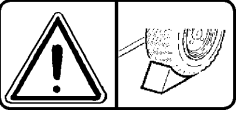
 <p>Before starting any operation, make sure you have read and understood this manual. All maintenance or modification work must be done according to the descriptions given in this manual. Failure to observe this may cause accidents or breakage of the machine.</p>	 <p>Switch off the tractor before acting on the pick-up.</p>
 <p>Keep clear of the cardan joint while the machine is running.</p>	 <p>Keep at a safety distance from the machine.</p>
 <p>The covers must be closed before starting the machine.</p>	 <p>Maximum rotation of the cardan shaft.</p>
 <p>You must insert or register adjust the belt only after removing the protection with the motor turned off.</p>	 <p>In the case of stopping the machine on especially soft ground you must use an additional foot support.</p>
 <p>Indicates the maximum vertical load on the towing eye.</p>	 <p>While closing the rear chamber it is forbidden to put your hands between the covers.</p>
 <p>Caution: When the machine is disconnected from the tractor, use the supplementary chocks.</p>	

BASIC RULES

For safety purposes and to ensure correct machine operation, before starting the equipment it is recommended to check the operation of both the machine and the tractor.



WARNING!

- Do not leave the machine unattended when there are moving parts.
- Do not carry out any maintenance, lubrication, adjustment, cleaning, or any other operation when there are moving parts.
- All operations must be done with the machine stationary and with the tractor's engine switched off.
- Do not use the machine without guards.
- Whenever the operator has to get off the tractor, he has to disconnect the P.T.O., switch off the engine, pull on the parking brake and wait for all the tools to stop completely before getting off. Getting back into the driver's seat, the operator needs to make sure that earth or mud does not make the controls difficult for him.
- The machine can only be used if carried by a suitable tractor and controlled by a suitable cardan shaft, which takes its motion from the tractor's P.T.O.; all other uses are strictly forbidden.
- Other persons in addition to the operator are not allowed on board the tractor.
- It is not allowed to carry persons or objects on the equipment.
- During normal work keep people out the range of action of the machine.
- When working on slopes, keep to the tractor manufacturer's instructions to avoid turning over. In any case reduce your speed and handle with care.
- Before unhooking the equipment from the tractor, lean it on the ground and stabilize it with the stabilizer.
- After unhooking, check the stability of the equipment.
- Do not push the product into the collection apparatus using your hands or feet.
- When transporting the machine it is necessary to use the customary signals.
- The firm declines all responsibility should the above instructions not be observed.

GENERAL SAFETY STANDARDS: USE CONDITIONS AND LIMITS



WARNING!

- The manufacturer of the ball joint or cardan shaft is responsible for such components. For the cardan shaft or ball joint, the manufacturer of the universal joint will issue the prescribed EEC conformity declaration, together with the machine.
- Become familiar with the controls, the correct use of the machine and learn how to turn off the motor quickly. Do not remain in the work area.
- It is important to keep animals and other persons away from the machine. Do not allow the machine to be used by children or unskilled persons.
- During operation, it is recommended to wear suitable clothing and heavy shoes (loose-fitting clothes are prohibited).
- Make sure that you have mounted the guards, safety devices and protection systems in accordance with the prescribed standards.
- Have defective or damaged parts repaired or replaced.
- Work during the day or with adequate artificial light.
- Stop the machine before crossing streets, paths or gravel-covered roads.
- If you collide with a heavy object or if the machine vibrates excessively stop the motor, check for damage and have skilled personnel make all the necessary repairs before re-starting the machine.
- When you decide to leave the tractor, turn off the motor and remove the ignition key from the instrument panel. Before getting close to the machine, wait for all moving parts to stop turning.
- Do not place hands and feet close to moving machine parts.
- Always keep in mind the use accident-prevention standards. Therefore, to ensure correct use, it is absolute essential to refer to the warning signals.

- Before starting any type of operation, the operator should become familiar with the machine, its parts and the relative functions and, especially, when driving on the road, must respect the current traffic rules and regulations.
- Always check that the machine is perfectly clean to avoid dangerous accidents. While working, never transport other persons on the machine.
- If the picker becomes jammed, clean it only when the motor is turned off.
- Be extremely careful when unloading and closing the binding chamber.
- Do not use the machine near other persons.
- The machine should be cleaned with the motor off and the machine stopped.
- Do not tamper with the controls and the safety systems.
- The machine must be assembled in accordance with the instructions.
- Use the necessary caution during machine assembly and disassembly operations or when disconnecting the machine from the tractor. Always check the loads per axle, the overall weights and dimensions allowed for transiting.
- Make sure that lighting, warning signal and protection devices have been installed and install them if they are missing.
- The machine running speed must be compatible with the environmental conditions and avoid any brusque steering movements while moving uphill or downhill. Do not work on very steep slopes.
- The machine can be started only when the relative protection devices have been installed.
- It is absolutely prohibited to remain in the work area and in the vicinity of the machine while it is operating and moving.
- Make sure that there are no persons near the machine during operations which may involve tilting hydraulic parts. The parts driven by external forces have sharp and pointed ends.
- If brakes and stop devices are not activated, it is absolutely prohibited to remain between the machine and the tractor.
- Do not operate the machine in closed rooms.
- The machine is equipped with wheel blocking wedges which must be used immediately each time the machine is disconnected from the tractor. These wedges are kept inside the container that houses the string roll.

**WARNING!**

- During operation, persons or animals should not get closer than 40 meters from the machine!
- Therefore, stay far away from the rear mobile chamber of the machine which expels the bales, thus creating a dangerous situation.
- Driver seat noise level: Leq. = 79,5 dBA. It is recommended to use protective earphones when using the tractor without a sound-proof cab (only if the noise exceeds about 85 dBA).
- When the machine is not working, it must be fitted the supplemental support foot, if the machine is left on soft ground (see safety labels pag.5).
- The machine described in this use and maintenance handbook should be repaired or disassembled, only by manufacturer authorized workshops.

POWER TAKEOFF**WARNING!**

- Only EC marked universal joints can be used with the machine and the user must follow the instructions contained in the "use and maintenance" handbook issued by the universal joint manufacturer.
- The protection bar and the universal joint protection hopper, as well as the power takeoff guard must be installed in the proper position.
- The cardan shaft can be mounted and removed only if the power takeoff is disconnected, the motor is off and only if the ignition keys are not inserted in the instrument panel.
- Make sure that the cardan shaft is installed properly; correctly install the protection bar and the relative protection hopper.
- Make sure that the chains are attached to the protection device of the cardan shaft to prevent it from turning by itself.
- Before engaging the PTO, check that the rpm of the machine is the same as that of the tractor PTO (540 rpm) and that the direction of rotation of the PTO is counter-clockwise. Make sure that there is nobody in the danger zone surrounding the machine.
- It is prohibited to insert the power takeoff when the motor is on.
- During work operations with the power takeoff it is prohibited to remain in the vicinity of the cardan shaft or the power takeoff and the power takeoff must be disconnected if the angles are too high.
- Do not get too close to the machinery even when the power takeoff is disconnected.
- To clean or lubricate the machine or to perform maintenance operations and repairs, turn off the motor, disconnect the power takeoff and remove the keys from the instrument panel. The cardan shaft, once disconnected from the power takeoff, must be held by the special support so that it does not touch the ground and become damaged or dirty.
- The P.T.O. protection casing must always remain at least 50 millimeters beyond the universal joint protection casing.

LIFTING THE MACHINE

To lift the machine use the special connecting holes located at the top of the machine (fig.1).

START-UP

Do the following before starting the pick-up baler:

Check all the lubrication and greasing points (see "Lubrication and Maintenance" p.11 and p.12). Make sure that the nuts and bolts have not become loose and tighten them, if necessary.

ATTENTION! Before putting in operation, check the oil and if necessary fill with oil SAE 90 (differential) the reduction gear box up to level (see "Lubrication and Maintenance" p.11 and p.12).

TRACTOR- BALER COUPLING

The pick-up baler is connected to the fixed bar of the tractor and is driven by the power takeoff.

Position the machine, by using and adjusting the support, on a horizontal plane so that the compression chamber is parallel to the ground. Couple the machine with the tractor in reverse gear, positioning the towing eye at the required height (adjusting the position of the tractor height, if necessary) making sure that it is properly connected.

Then raise the support of the baler, by placing it in the working position (fig. 1bis).

The coupling eye of the baler must be adjusted as shown in Fig. 1bis / fig. 1ter.

The coupling fork of the tractor and the towing eye of the baler must be adjusted so that the compression chamber is parallel to the ground. The eye must be about between 30 and 60 cm from the power takeoff and the cross position of the same eye must place it at a distance between 0 and 5 cm to the right of the axis of the tractor power takeoff (fig.1 bis / fig. 1ter)

Incorrect coupling to the tractor will make the cardan transmission joints operate under abnormal loads and will lead to abnormal operation of the baler and may damage the relative parts.

When the machine is in the field, before starting the baling operation, move the drawbar of the baler to the left side into the working position (see the instructions on the sticker applied on the front side of the baler and fig.1/A), then mount the cardan shaft supplied with the machine as standard (or the wide angle shaft as optional equipment) and make sure that it is perfectly locked into position on the power take off and that in any position it will not pull out or jam.

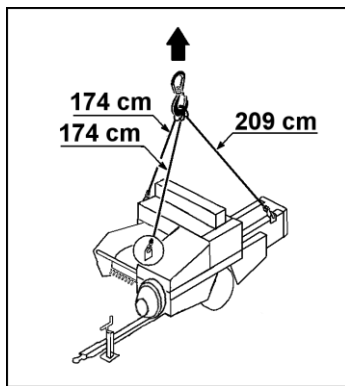

Fig. 1

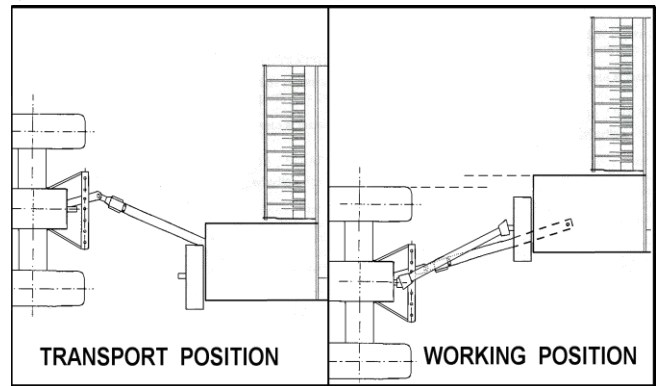

Fig. 1/A

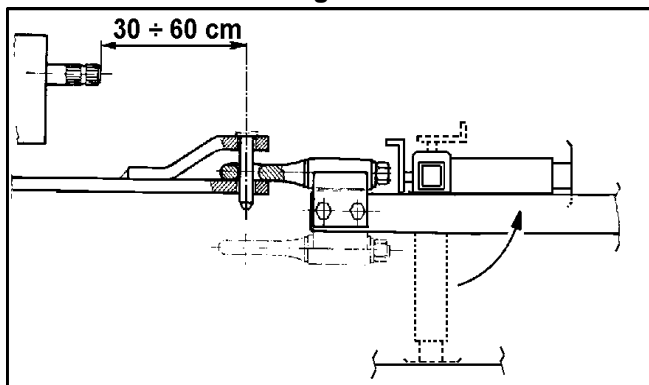

Fig.1bis

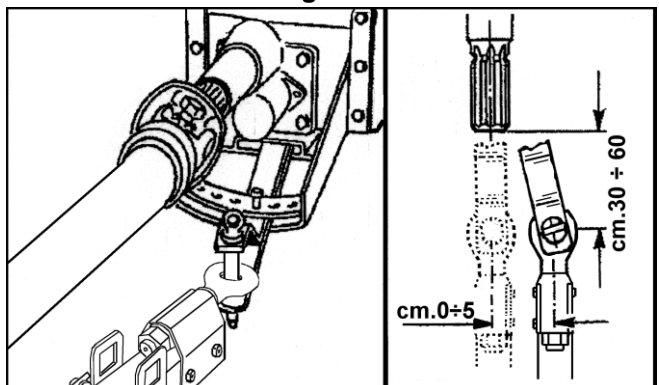

Fig. 1ter

ATTENTION!

Avoid tight curves while operating the baler. To avoid damage to the cardan shaft in tight curves, disconnect the power takeoff of the tractor to avoid this maneuver it is necessary to use the wide angle cardan shaft that is supplied as optional equipment.

PROTECTIVE COVERS

WARNING!

All protective covers must always be closed before starting the machine and should be opened only after stopping the machine, turning off the tractor motor and removing the ignition key.

MOUNTING THE TWINE (CORD)

1. Insert into the special container, natural twine reels which must be type 180 - 200 meters per kg or plastic twine reels, type 350 meters per kg. Make sure that the reels are located in the container so that by pulling the central end of the twine it unwinds counterclockwise. This will prevent the twine from becoming tangled while it is unwinding. Place the reels and make the joints carefully following the instructions in fig.2.

2. Thread the twine as indicated in Fig. 2 and Fig. 3.

Each twine must come out of the clamp (2 fig.2 / 2 fig.4bis) when subjected to a force $F_1 = 2 \div 3$ kg (fig.2 / fig.4bis) and must slide along its path out of the needle when subjected to a force $F_2 = 10 \div 14$ kg. (fig. 4bis). If necessary adjust the pressure of clamps 2 fig.2 / fig.4bis and the position of springs 5 fig.2 / fig.4bis.

3. Tie the ends of the twine to the bottom cross bar of the compression chamber (Fig. 3).

4. Completely lift lever 1 shown in Fig. 4, by turning metric wheel 2 in Fig. 4 to engage the binder.

5. Rotate the flywheel counter-clockwise in order to start the needles/binder system until the twine is blocked in the cord holder disc (1 fig.15 p.19/ 5 fig.18bis p.26) of the binder itself. Then keep on rotating the flywheel until the needles are in their resting position. (the needle arm must be in the resting position - needles retracted).

6. Remove the two pieces of twine that are still tied to the cross bar.

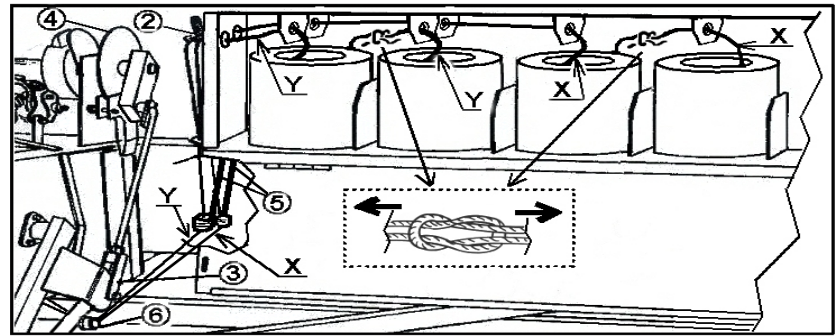

Fig. 2

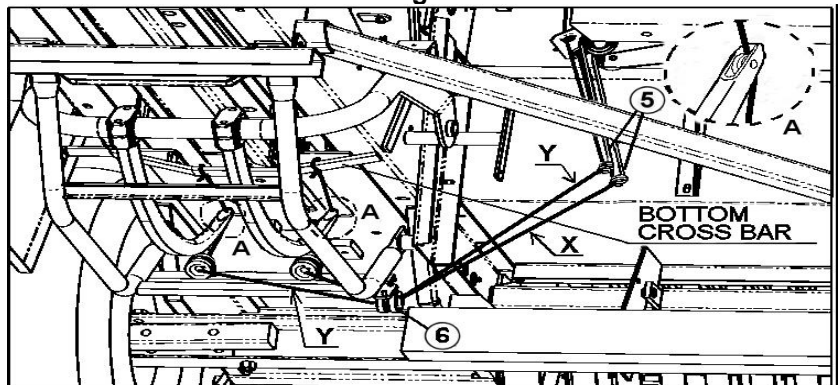

Fig. 3

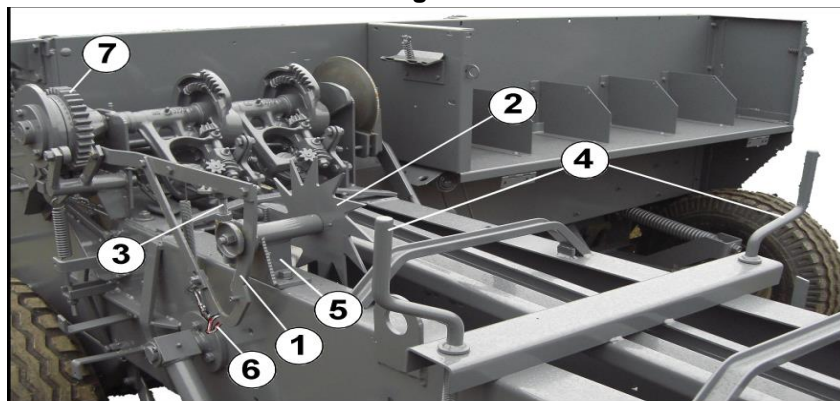

Fig. 4

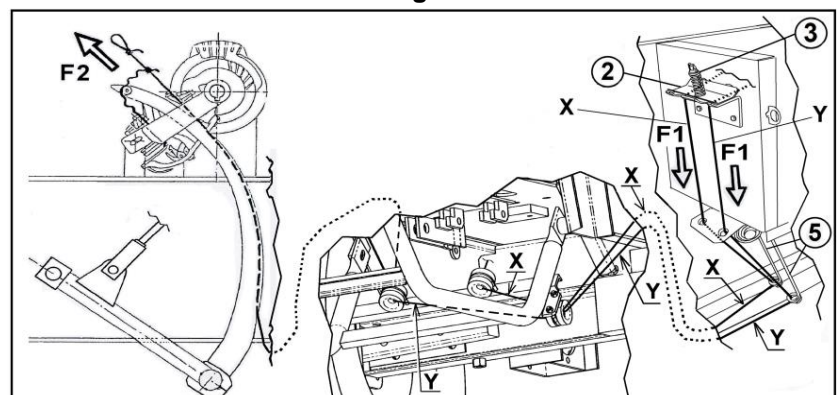

Fig. 4 bis

OTHER STARTING PROCEDURES

Do the following to start the machine:

1. Lower the bale unloading platform (n°4 fig. 25) and reduce the tension of the compression springs of the compression chamber using the handles 4 shown in Fig. 4.
2. Adjust the height from the ground of the pick-up in relation to the material to be collected and the type of soil on which the baler will operate by using ratchet 1 shown in figure 5 after releasing rod 2 shown in Fig. 5.

We suggest to adjust the pick-up height in such a way that the tips of the pick-up springs are at about 2÷3 cm from the ground to collect hay and 10÷20 cm from the ground to collect straw.

3. Engage the power takeoff of the tractor after connecting the cardan shaft and set the baler at 90 strokes per minute. (It is simple to check the number of strokes - just count the number of rpm of the feeding forks or the number of strokes of the plunger).

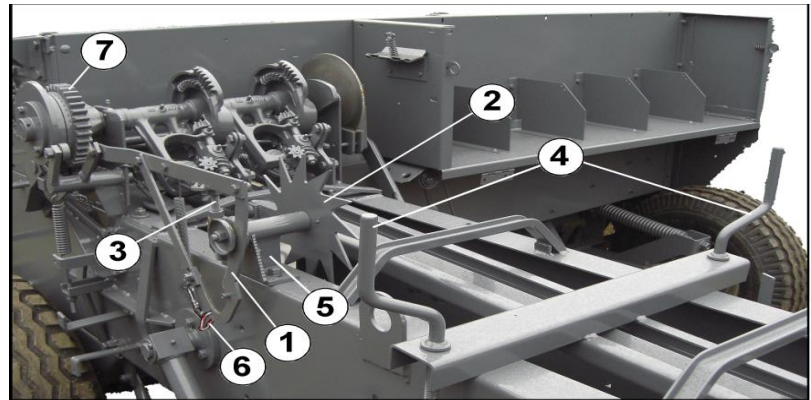

Fig. 4

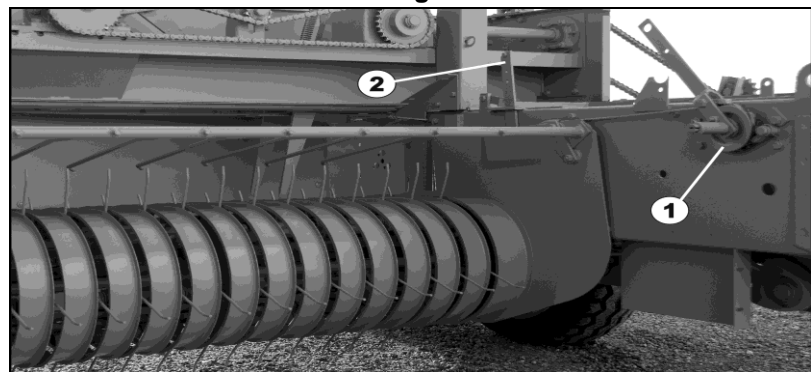

Fig. 5

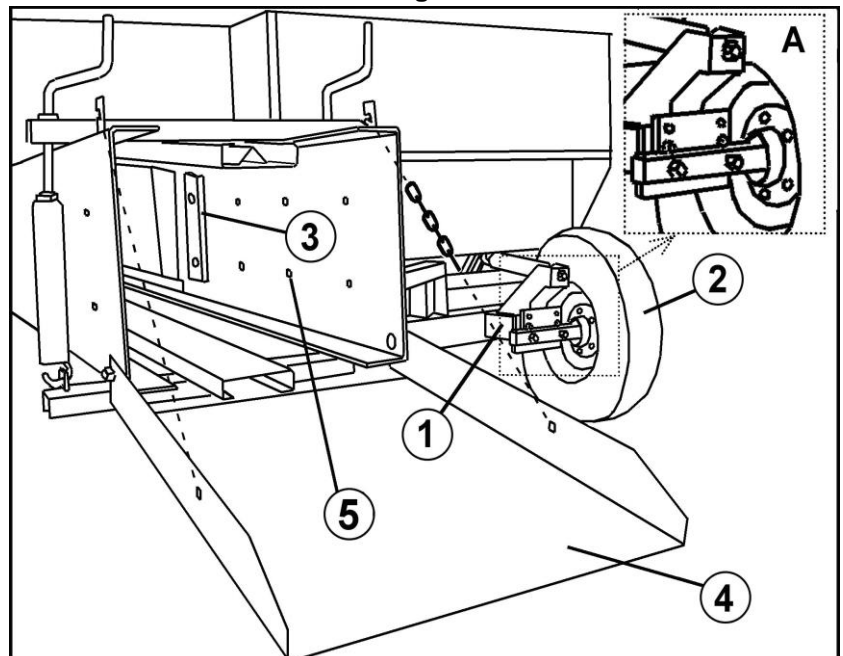

Fig. 25

LUBRICATION AND MAINTENANCE

The balers are built to require a minimum lubrication. However, it should be recalled that the time required for lubrication is not wasted since it protects the machine against costly breakdowns and considerably extends its service life.

To perform a correct lubrication pls see the following lubrication and maintenance chart.

ATTENTION! The machines are delivered with oil. However before putting in operation, verify the oil and, if necessary, introduce oil SAE 90 (differential) in the main reduction gear carter up to level (see below "Lubrication and Maintenance Chart"). Expected max. quantity of oil: about 2 lt.

The parts to be lubricated and greased are identified by special stickers applied on them.

These parts are shown in the following "Lubrication and Maintenance Chart".

RECOMMENDED LUBRICANTS:

Premium viscous grease – Oil SAE 90-120 (differential).



WARNING!

Hydraulic piping may rupture. Therefore, check for any leakage of hot oil under pressure.

The max. operating pressure is 330 bar.

The bursting pressure is 1450 bar.

The piping and the hydraulic components conform with prEN 982.

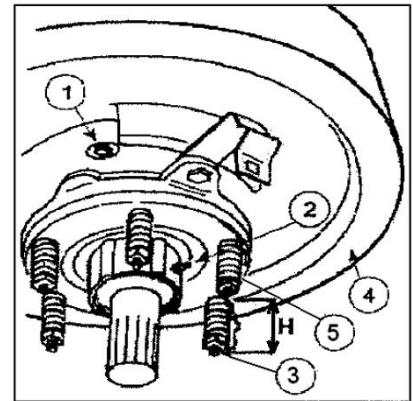

Fig. 6



WARNING!

Before performing any lubrication or maintenance operation, you must turn off the tractor engine and remove the key from the control panel.

LUBRICATION AND MAINTENANCE CHART

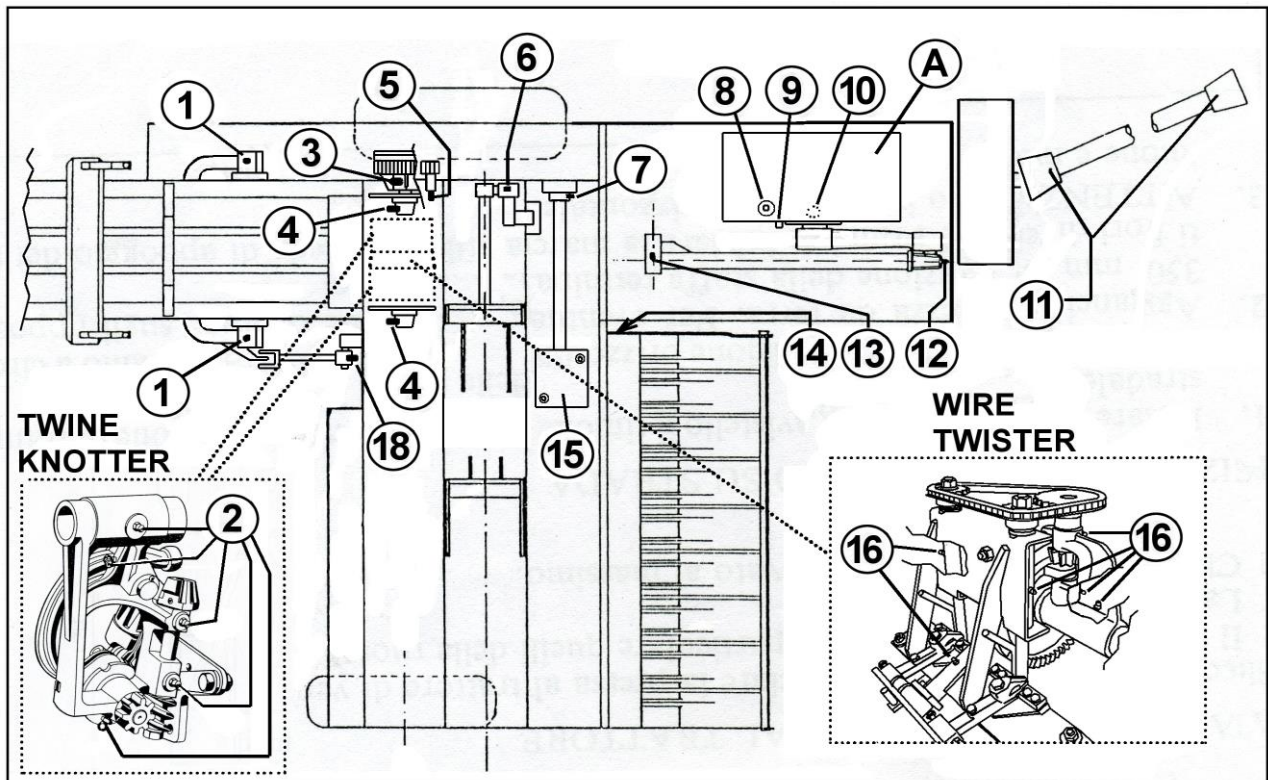

Fig. 6 bis

PERIODS	PARTS TO LUBRICATE	MAINTENANCE WORK
At the beginning of the season	Clean the chains with naphtha and lubricate them with oil mixed with naphtha (30% oil and 70% naphtha). Check the main reduction gear carter (A in Fig. 6bis), verify and, in case, fill in oil SAE 90 up to the level stopper / cap (n° 9 Fig. 6bis)	Check all the bolts and the bushings of the safety bolts. Clean the knotters and all the binder area. Examine the plunger knife and the compression chamber knife; if they are splintered, replace them. Verify the clearance between knife and counter-knife, in case reset the prescribed clearance. (see p. 22)
Every 8 working hours	Grease the following points : 1 , 2 , 3 , 4 , 5 , 6 , 11 , 13 and 16 (see Fig. 6bis).	Examine the needle slots in the compression chamber, examine the plunger slots and, if necessary, clean them of any stones, compressed material or other foreign bodies.
Every week	Grease the following points : 7 and 12 (see Fig. 6bis).	Check the efficiency of the needles brake and in case adjust screw 3 Fig.9. Check the air pressure in the tyres. Check the wheel locking bolts and any other bolt in the machine. Verify the correct distance and alignment of the plunger knife with the chamber knife and, if necessary, act on the bolts to set them (see p.22). Check all the chains and belts and, in case, tension them.
Every year	Grease the interior of the pick-up cam (n° 14 Fig. 6bis). Check the interior of the tapering coupling box (n° 15 Fig. 6bis) and, in case, add some grease. The oil in the main reduction gear carter must be changed every year, using the draining cap (n° 10 Fig. 6bis) and the filling cap (n° 8 Fig. 6bis)	

**WARNING: MAINTENANCE SAFETY INSTRUCTIONS**

- Disconnect the tractor power takeoff, turn off the motor, remove the keys from the instrument panel; now you can continue with the maintenance, cleaning and repair operations.
- Always use the blocking or closing devices before performing any maintenance or repair work.
- To replace any equipment, use suitable gloves and tools. To ensure machine stability, it is recommended to perform all operations on stable support elements.
- Replace inadequate protection devices and remove grease and oil as soon as it becomes necessary.
- If electric welding is performed on the machine-tractor coupling, make sure to disconnect the generator and battery cable.
- Check that the spare parts are original, i.e. those that are recommended by the manufacturer and check at the beginning of each job that the screws are tightened to prevent them from becoming loose.

SAFETY DEVICES

All the baler parts are protected by devices designed to interrupt the transmission when abnormal operation occurs.

CLUTCH ON THE FLYWHEEL

The clutch on the flywheel is designed to protect the cardan transmission shaft. It should never slip during normal operation of the baler.

The clutch torque limiter on the flywheel usually comes with a standard setting of 59 daNm and springs 5 fig. 6. that are 46.9 mm. long ($H = 46,9$ mm) .

It can be adjusted by means of bolts (no. 3 Fig. 6) which compress the springs 5 Fig. 6 (which should never be fully tightened). If the friction plates are in good conditions, the correct height H must be 46.9 mm. The free release device is lubricated by means of greasing nipple n° 2 Fig. 6, when present.

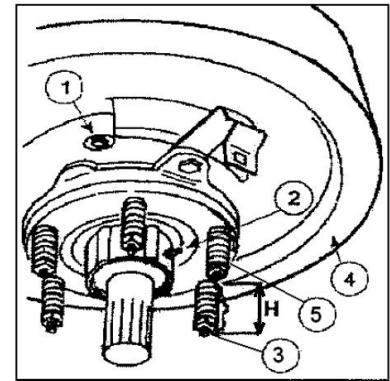

Fig. 6

SAFETY BOLT ON THE FLYWHEEL

This bolt is designed to protect the main reducer against overloads.

The bolt marked 8.8 is 8 x 60 mm and is made of material with resistance of 80 kg/mm² (no. 1 Fig. 6).

It comes into action when the layer of the material that the piston knife must cut when baling is too thick and generates excess cutting force, or when the binder needles, during the binding operation, did not come out at the right time from the compression chamber and could not return the piston pawl (no. 1 Fig. 7).

Frequent breaking of the safety bolt may be caused by the following:

1. Incorrect knife adjustment (Fig. 8) or bad condition of their cutting edge.
2. Too much compression of the bales with strong feeding or too moist crop.
3. Piston does not slide well due to incorrect adjustment of its guides.
4. Incorrect adjustment of the piston pawl (no. 1 fig. 7 / fig. 13ter p.16)
5. Bolt cutting bushes bent or broken or out of their correct seating.
6. Incorrect adjustment of the needle brake disk of fig. 9.
7. Malfunction of binder engagement device (bell gear n°4 fig. 9 or cam 5 fig. 9)
8. Breaking of the shear (safety) bolt no. 10 – Fig. 12 – on the binder control gear.

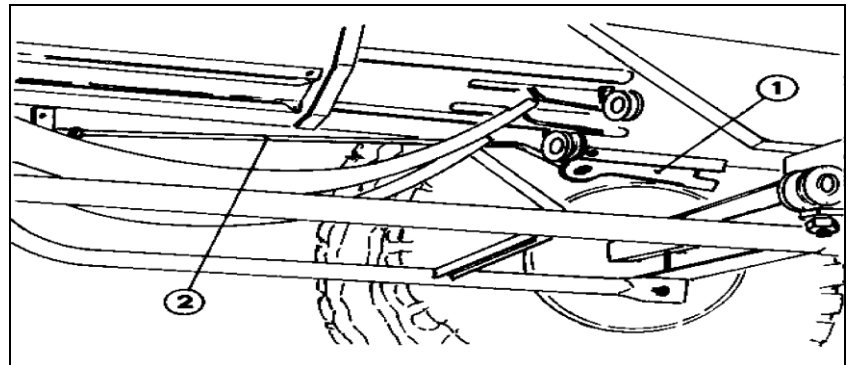

Fig. 7

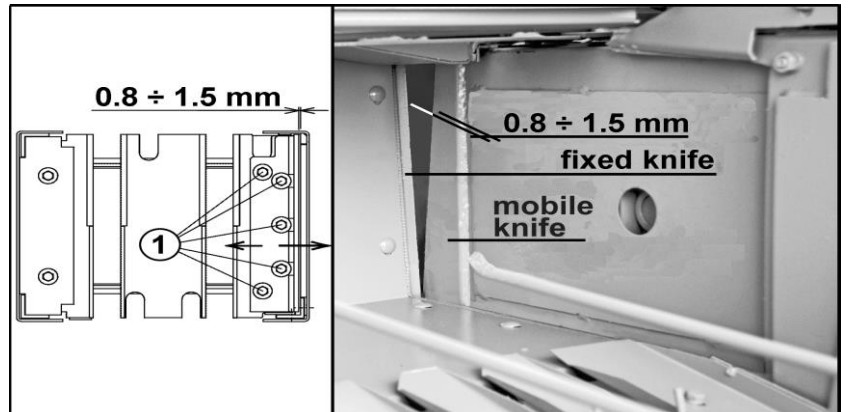

Fig. 8

ATTENTION!

After the first 15-20 hours of service it is recommended to check that the needle brake is operating properly. To adjust it, use bolt 3, Fig. 9.

To check that the needle brake works properly - after engaging the binder and starting the baler by the tractor at normal rotation speed - when the needle arm is in its resting position, lever 3 fig. 14 p.20 must match and cling to the binder engaging pawl 2 fig.14 without any

clearance



WARNING!

To extend the service life of the safety bolt, check that it is properly tightened. When the safety bolt is cut, wait until the flywheel stops before replacing the bolt.

SAFETY ON THE PICK-UP CONTROL SHAFT

The same pick-up control belt protects the various picker parts.

It should never slip during normal baler operation.

It slides when the pick-up forces against excessive resistance.

It can be adjusted using the tightening device (no. 8 Fig. 12).

SAFETY BOLT BINDER CONTROL AND NEEDLES

This bolt (no. 10 – Fig. 12) is designed to protect the various parts of the binder in the event of abnormal resistance in the movement of the binders or upstroke of the needles.

The bolt marked 8.8 is Ø 5x45 mm* and is made of material with resistance of 80 kg/mm². The breakage of this bolt (no. 7 fig.9) can be caused by the following:

1. The movement of the knotting mechanism is hindered due to spindle or wearing plane seizure caused by insufficient greasing or by overlapping gear teeth due to excessive clearance or by other possible causes that may block the drive or movement of the binders.
2. The needles, while moving, hit an obstacle due to rough ground.
3. The needles, being shifted from their correct setting, hit against some parts of the baler.
4. The needle, while moving upward, can be blocked by tangle twine (or iron wire).
5. Some problems may occur in the twine (or iron wire) passages (i.e. some passages may be worn down or don't work correctly).
6. The adjustable twine clamp (no. 2 fig. 2) is too tight so that the twine, jointed or not well coiled and tangled doesn't slide correctly. Therefore the needles can be stopped when moving upward.

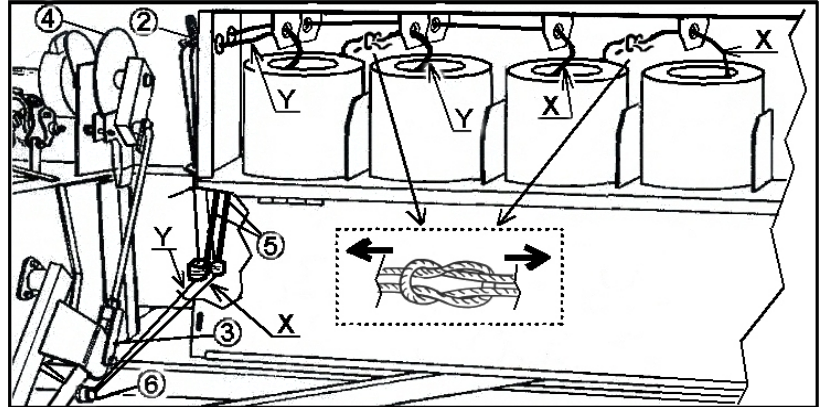

Fig. 2

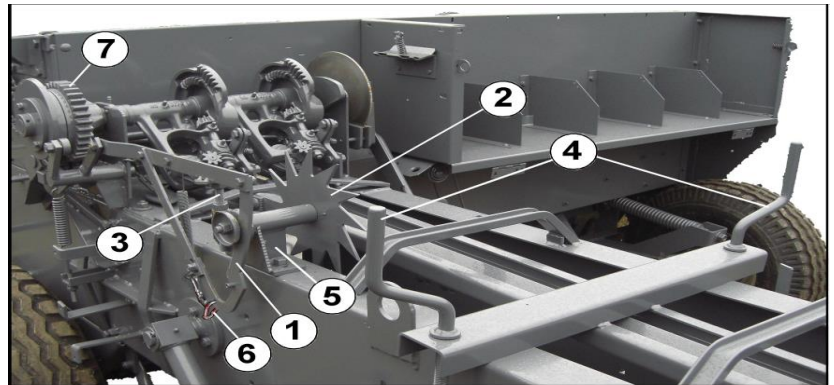

Fig. 4

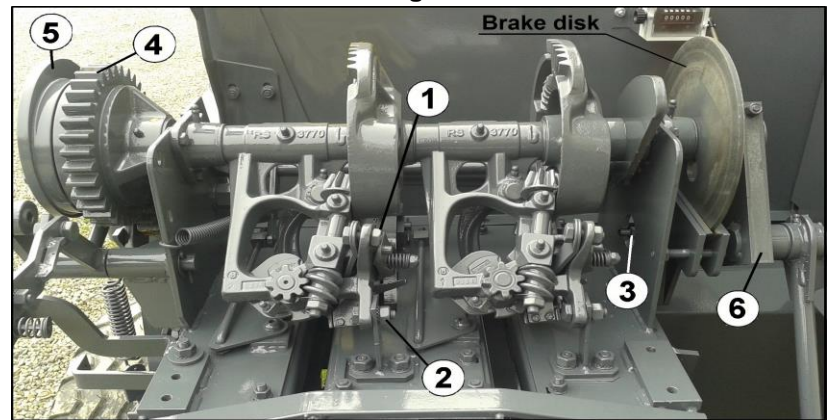

Fig. 9

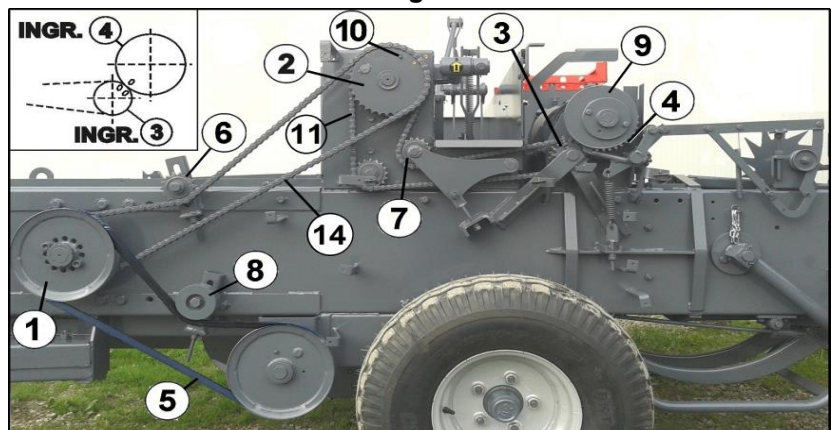

Fig. 12

*If an iron wire or 3-wire binder is used, this safety bolt may be replaced with a $\varnothing 6$ class 8.8 bolt – R = 80 kg/mm² placed at a reduced distance with respect to the rotation center of gear 2 – Fig. 12.



WARNING

Before performing any maintenance work on the binding device unit use the manual device to avoid engaging the binder and consequently the needles.

This means to fix lever 1 fig. 4 by means of chain 6 fig. 4.

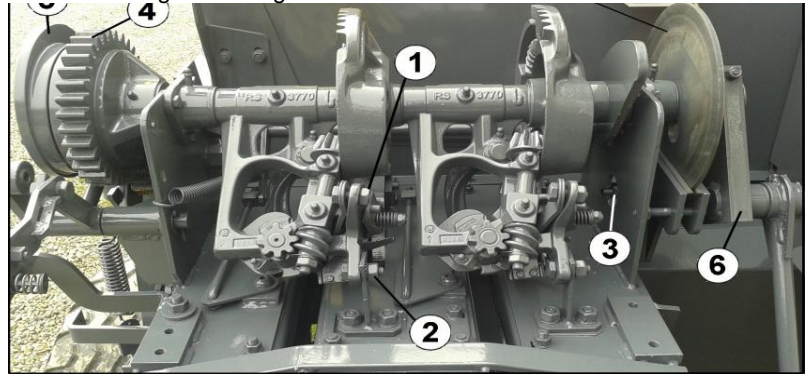

Fig. 9

FORKS SAFETY BOLTS

These bolts are used to protect the feeding forks if they create abnormal resistance. The bolts marked 8.8 are $\varnothing 8 \times 50$ mm. for the first fork and for the second fork and are made of material with resistance of 80 kg/mm² (no. 1 and 2 Fig. 10). They operate when the forks, while moving, encounter resistance due to picking up a foreign body, an excessive amount of product or when the first fork collides with the piston side because of total lack of synchronization.

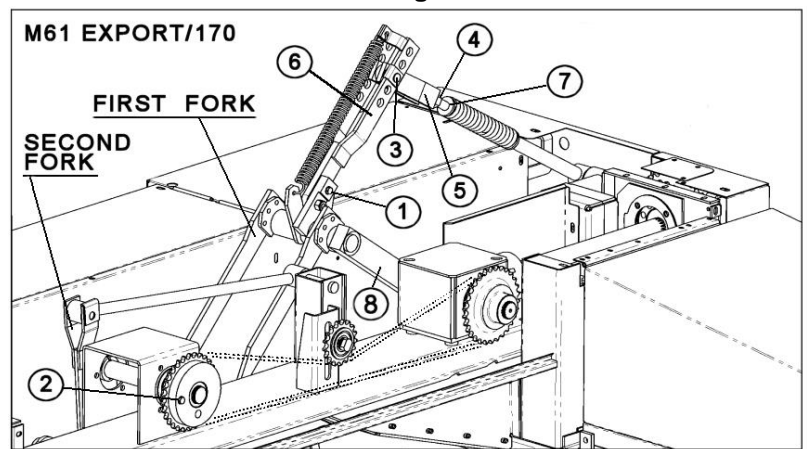

Fig. 10

JAMMING

If a large jamming occurs in the feeding device, disconnect the power takeoff, turn off the tractor, remove the key from the instrument panel and manually clear out the jam.



WARNING!

Do not get too close to the machine when it is jammed except if the power takeoff is disengaged, the motor is off and the key has been removed from the instrument panel of the tractor.

PISTON PAWL

This component is designed to protect the binding device needles.

It consists of a metal tooth (no. 1 Fig. 7) controlled by the needle arm by means of coupling device 2 Fig. 7.

It is correctly adjusted when, being the baler phased, during the return movement of the needles, the point of those needles and the pawl are flushed with the bottom edge of the compression chamber, while the distance between the carriage striker (plunger) and pawl is 9-11 cm. (fig. 13ter).

Use nuts 3 shown in Fig. 11 to adjust the pawl position.

When the flywheel safety bolt (no. 1 fig.6) is cut as the pawl is activated, it causes, excluding pawl poor adjustment, may be:

1. The shear bolt of the binder and needle control crank (no. 10 Fig 12) has been cracked off, so the needles could not be removed from the compression chamber.
2. The tractor power takeoff has been disconnected with some material left inside the machine incompletely pressed by the plunger and the plunger continues its run by inertial force while the needles begin their binding movement.

ATTENTION!

Never disconnect the power takeoff until the feeding and pressing equipment (pick up + forks + piston) are completely clear and free in their movements. Make also sure that the binder is not engaged.

3. The needles are not properly synchronized with the piston (fig.13bis).
4. Incorrect adjustment of the needle brake disk of fig. 9.
5. Malfunctioning of the binder engagement device (bell gear n° 4 fig. 9 or cam 5 fig. 9)

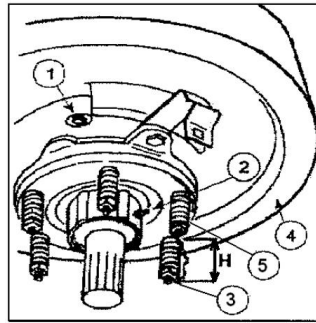

Fig. 6

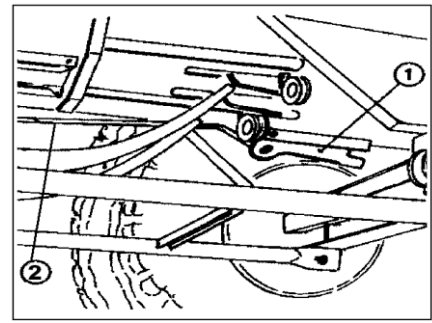

Fig. 7

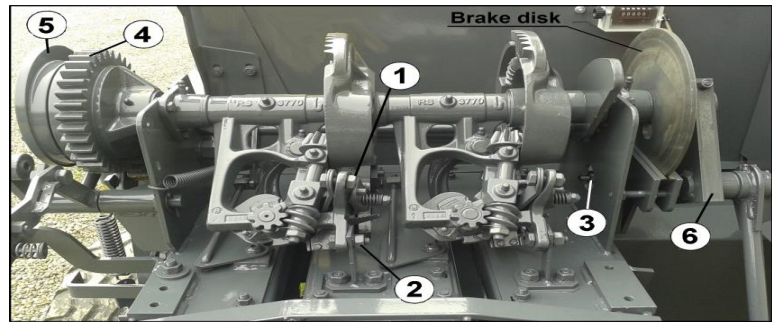

Fig. 9

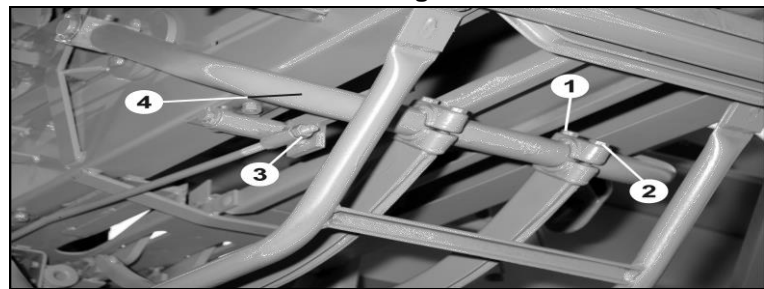

Fig. 11

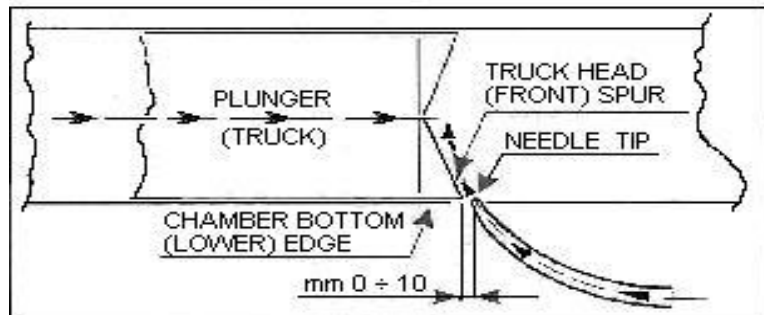

Fig. 13 bis

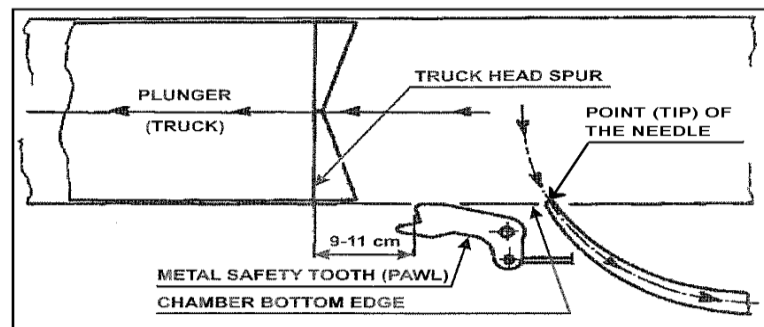

Fig. 13 ter

PHASE

The phasing of the machine is carried out in two steps: first, phasing of the forks with the plunger, then phasing of the binder/needles with the plunger.

A) Phasing of the forks with the plunger

1. Linking is carried out by means of chain between chain gear 1 Fig. 12, free on its own axis by unscrewing special socket head screw, **and** the gear driving the forks of double gear 2 Fig. 12.
2. By rotating the flywheel (n.4 – fig.6) anti-clockwise by hand, the plunger is moved forward and the tip of the upper In these conditions, gear 1 fig. hooks positions flush with the fork teeth passage slot (See figure 12 bis). With the plunger in this position, the crank of the first fork (n.8 – fig.10) is rotated to have a distance of approximately 40-60 mm from the head hook of the plunger (see figure 12 bis). In this conditions the gear n.1 – fig.12 is made integral with its axis by means of the special socket head screws.

The system of opposite multi-hole flanges makes it possible to lock gear 1 fig. 12 in the required position with minimum deviation.

3. Once the phasing of the 1st fork with the plunger has been obtained as mentioned above, you can continue with the phasing of the 2nd fork by connecting gear 2bis and gear 2ter by the chain (Fig. 13) after placing the crank of the 1st fork inclined in relation to the crank of the 2nd fork as shown in picture 13.

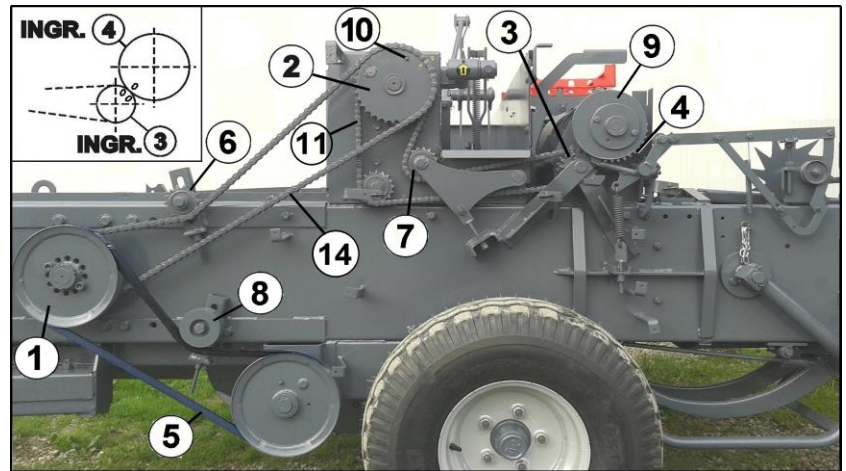

Fig. 12

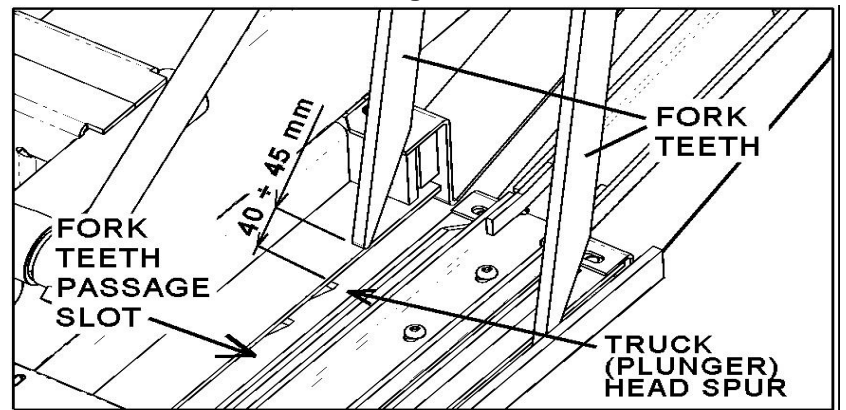

Fig. 12 bis

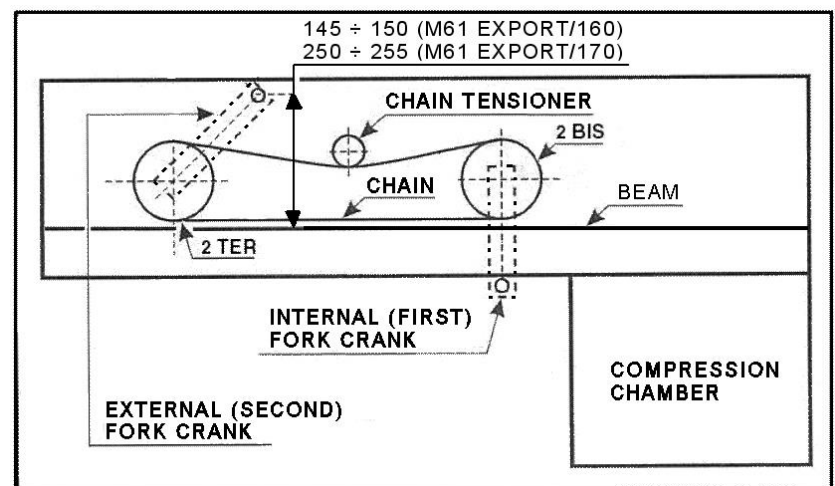

Fig. 13

B) Phasing of the binding device/needles with the plunger

Once the fork/plunger phasing has been carried out, it is possible to proceed to phasing of the binding device/needles with the plunger, as follows:

1. Before carrying out the phasing activities, ensure that chain 11 of fig. 12 is disconnected.
2. Place the needles in standby position by moving needle arm 4 fig. 11 backwards up to the upper stroke end.
3. Carry out coupling of the binding device bringing the sector lever (n° 1 fig. 4) to its maximum height by rotating bale spacing star type wheel 2 fig. 4.
Then rotate manually bell gear n° 7 fig. 4 counter-clockwise until it is locked in the position of binding shaft dragging.
4. Keep on rotating bell gear 7 fig.4 counter-clockwise, moving it repeatedly by a series of “clicks”, until the needles arm is lowered into such a position as to have the needle tips at the level of the lower edge of the compression chamber (fig. 13bis).
5. Then, by rotating the flywheel (n° 4 fig. 6), counter-clockwise, bring the plunger into such a position as to have its front spurs at approximately $0 \div 10$ mm. from the tips of the previously positioned needles (see fig. 13bis).
6. With the needles and the carriage in that position, it is necessary to mount chain 11 of fig. 12 and energize tensioner 7 of fig. 12.

Once the sequence of operations A and B is carried out, the machine is fully phased.

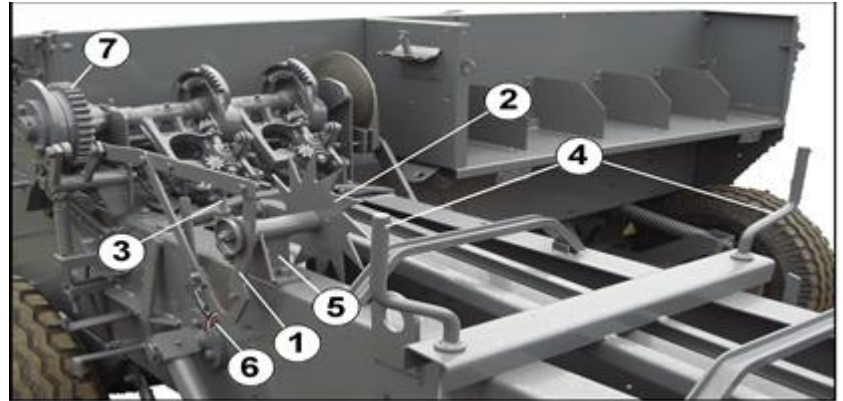

Fig. 4

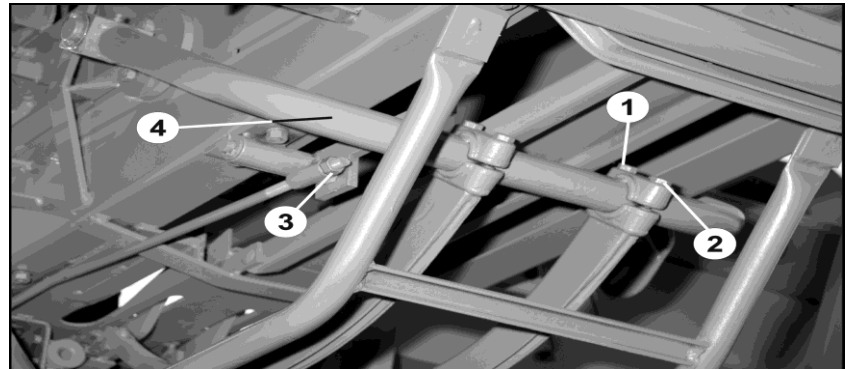

Fig. 11

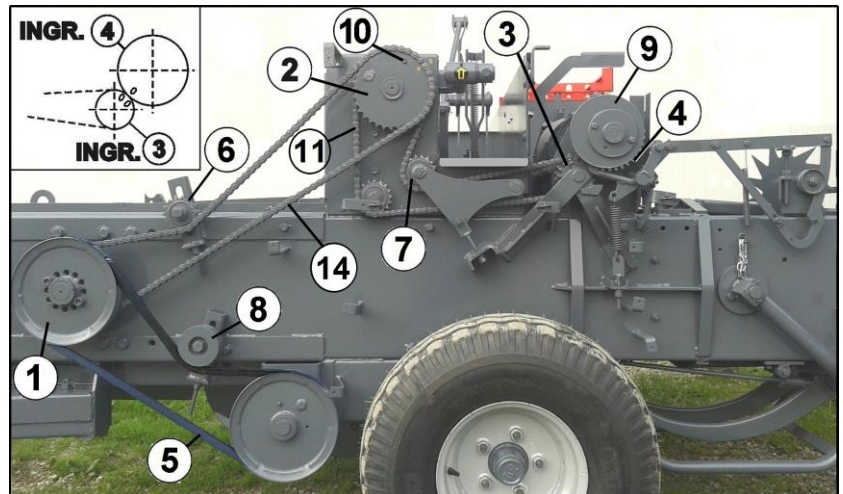

Fig. 12

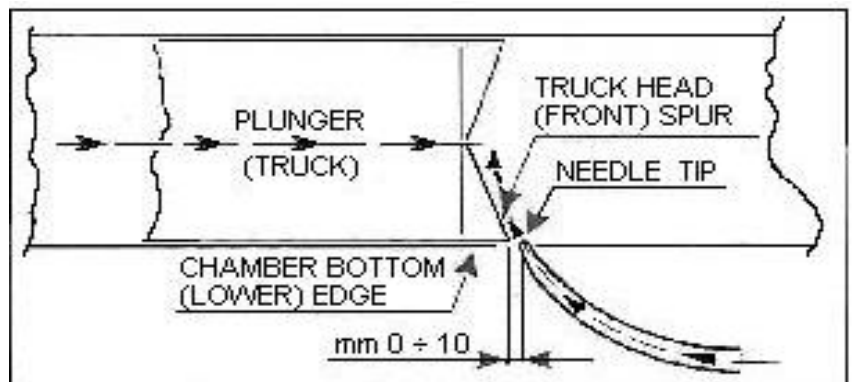

Fig. 13 bis

ATTENTION!

The phase control is facilitated by the referenced punched yellow marks on fixed and moving parts.

These marks must correspond to one another when the machine phasing is correct.

Always keep the main chains taut using the tensioning devices (n°. 6-7 fig. 12) and lubricate them as specified. In fact, when the chain is slackening, it becomes longer and could also come out of the gear teeth. In both cases, this situation could cause out phasing of the machine.

If necessary recover any excessive lengthening of the chain, by making the chain "skip" one gear tooth or shortening the lengthened chain or replacing it with a new chain. Or, in the case of the main chain n°.14, block gear 1 fig. 12 in a new position using the specific hex-keys if necessary combining this last action with those previously described.

ATTENTION!

If it has been necessary to disassemble the entire binder, before phasing, it is advisable to reassemble the binder respecting the position between gear 3 and gear 4 as indicated in Fig. 12 (the O marked on gear 4 must be positioned between the two Os marked on gear 3).

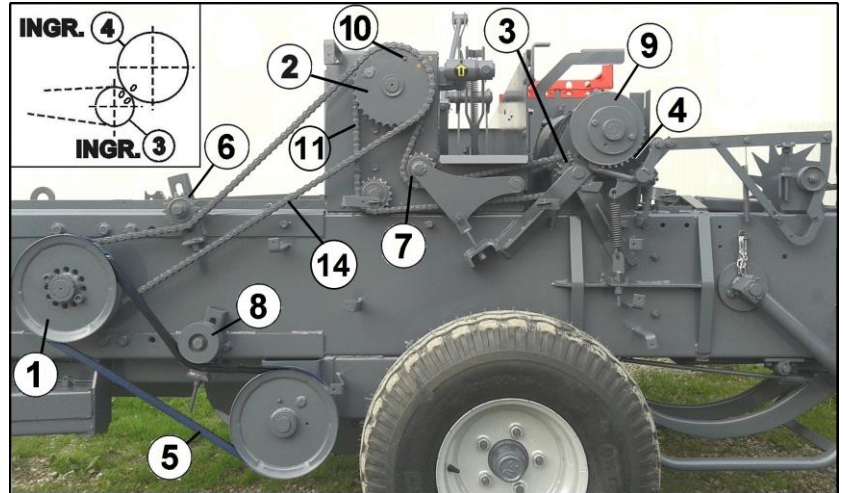

Fig. 12

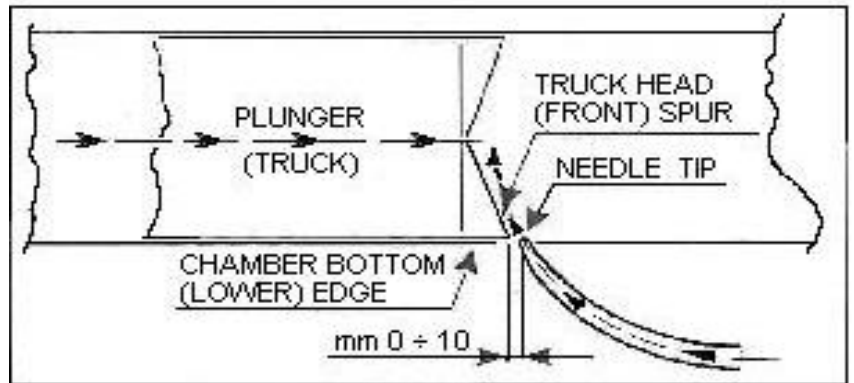

Fig. 13 bis

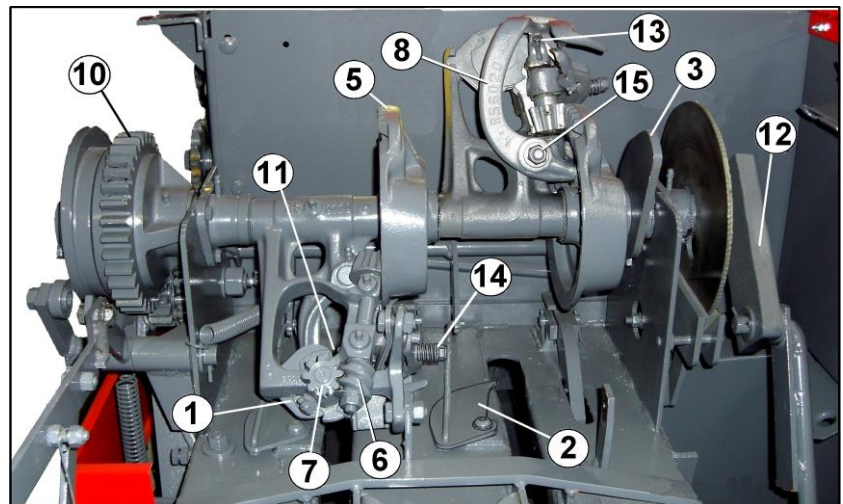

Fig. 15

BALE CHARACTERISTICS

BALE LENGTH

Adjustment is made on the screw adjuster (no. 3 Fig. 4) after having loosening its fixing nut.

To obtain shorter bales, unscrew upwards, towards the top.

To obtain longer bales, screw downwards, towards the bottom.

The bales length may be varied from 40 up to 130 cm.

Irregular bale length can be caused by the following reasons:

1. Irregular feeding of the baler, especially when operating in a stationary place.
2. Variation of shape of arch lever (no. 1 Fig. 4). Its shape is perfect when all its bent side is located at the same distance from the rotation fulcrum (no. 1 Fig. 14). To avoid arch deformation, never try to set the arch lever in its rest position after the binding device has been connected.
3. Axis of the trip lever (no. 3 Fig. 14) is blocked in its bushing (due to gripping).
4. Wrong position of the metering wheel support (no. 5 Fig. 4). This may determine incomplete run of the arch lever and therefore anomalous length of the bale.

The correct position of the metering wheel support is the one in which the return movement to the arch lever starting position (no. 1 fig.4), the maximum distance between the external profile of the mentioned arch lever teeth and the external profile of the teeth of the reel connected with metric wheel 2 fig.4 must be between 2.5 and 3 mm. Check that, being arch lever 1 fig.4 in its resting position, the top of trip lever 3 fig. 14 fully matches the surface of dog trip 2 fig.14. It is possible to adjust the position of the metering wheel support by using its own fixing bolts.

BALE WEIGHT

The bale weight is determined by the quality of the material to be pressed, by the density and the length of the bale.

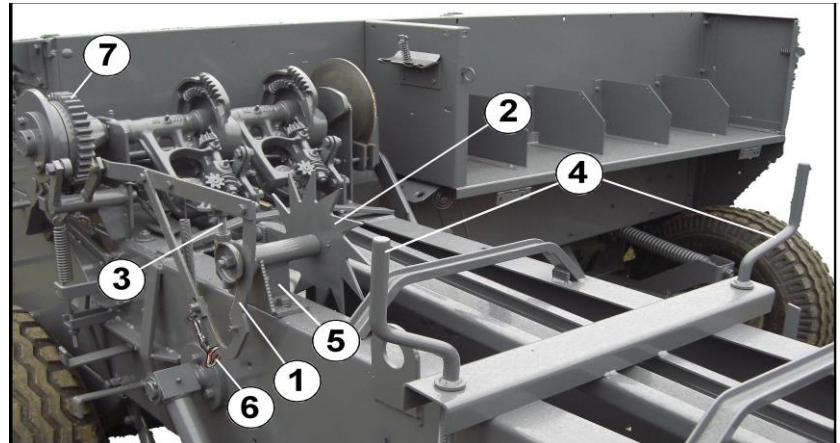

Fig. 4

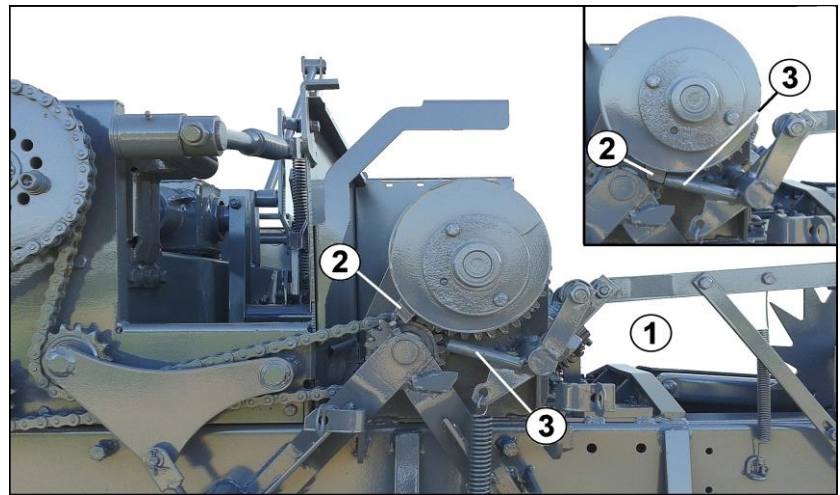

Fig. 14

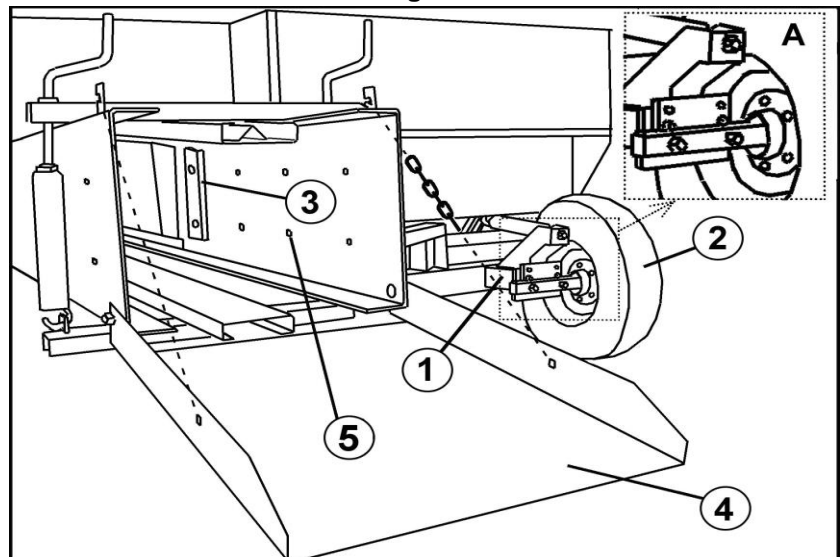

Fig. 25

To increase the density, straw-stop wedges (no. 3 Fig. 25) are fixed in the respective holes of the compression chamber (no. 5 Fig. 25). Usually density is adjusted by using handles 4 Fig. 4.

A variation of density is also possible by changing the intensity of feeding: the higher the feeding the lower the density.

When there is humidity, during evenings and nights, it is necessary to reduce the pressure induced by unscrewing the handles (no. 4 fig.4).

Experience will teach the operator the correct regulation in order to obtain the desired bale weight under any baling

conditions.

BALE SHAPE

The first rule to obtain bales of perfect geometric shape is to feed the baler steadily, with no overloads.

In the event that the bales don't have a perfect geometric shape, adjust the position of the first fork (fig. 10).

A) If the bales come out of the compression chamber like fig. 26 bis / A, (I.E. the bales are longer on the outer side of the compression chamber), it is necessary to move adjustable fork 5 - Fig. 10 upwards by fixing pivot 3 Fig. 10 in one of the holes towards the top of rod 6 Fig. 10.

If this is not sufficient, it is necessary to shorten rod 7 Fig. 10 by adjusting nut 4 Fig. 10 after adjustable fork 5 Fig. 10 has been disconnected from rod 6 Fig. 10.

This situation mainly occurs baling short crops.

B) On the contrary, if the bales come out of the compression chamber like Fig. 26bis / B, (I.E. the bales are longer on the inner side/knives side of the compression chamber), it is necessary to move adjustable fork 5 / Fig. 10 downwards by fixing pivot 3 / Fig. 10 in one of the holes towards the bottom of rod 6 Fig. 10.

If this is not sufficient, it is necessary to lengthen rod 7 / Fig. 10 by adjusting nut 4 Fig. 10 after adjustable fork 5 / Fig.10 has been disconnected from rod 6 Fig. 10.

This situation mainly occurs baling long crops.

Attention: see the instruction sticker on rod 6 fig.10 on the baler.

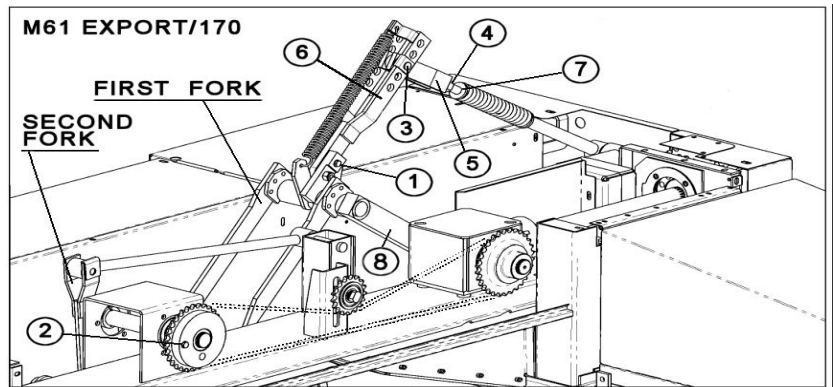

Fig. 10

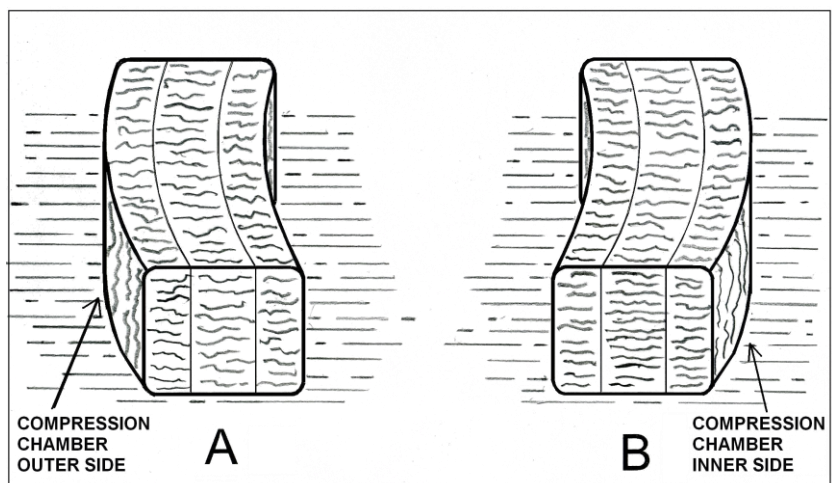

Fig. 26 bis

ADJUSTMENTS

BINDER BRAKE ADJUSTMENT

This brake (Fig. 9) is designed to make the motion of the binder uniform during the binding cycle and to keep it still when it doesn't work.

The adjustment is performed by turning the special screw to increase or decrease compression on its spring 3 Fig. 9 (see also p.13).

PLUNGER KNIFE ADJUSTMENT

The knives (Fig. 8) are designed to separate the subsequent layers of material introduced into the compression chamber by the feeding forks.

It is very important to adjust the knives to obtain quality bales and to avoid frequent breakage of the safety bolt on the flywheel.

The distance between the fixed knife attached to the baler chamber and the mobile knife attached to the piston, should range between 0,8 mm and 1,5 mm. to the top of the compression chamber, while to the bottom of the compression chamber it must be the minimum distance needed to allow free, unblocked running of the plunger in the compression chamber (fig.8).

After checking the adjustment of the plunger side guides (see below for further details), the distance between the knives can be varied by changing the position of the angular knife connected to the piston by means of bolts in the slots (n° 1 fig. 8).

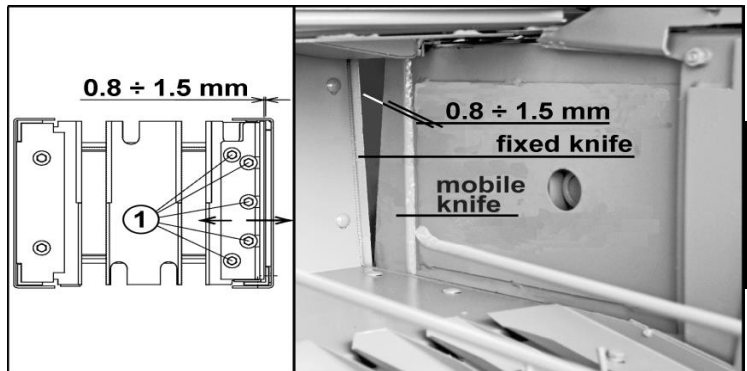

Fig. 8

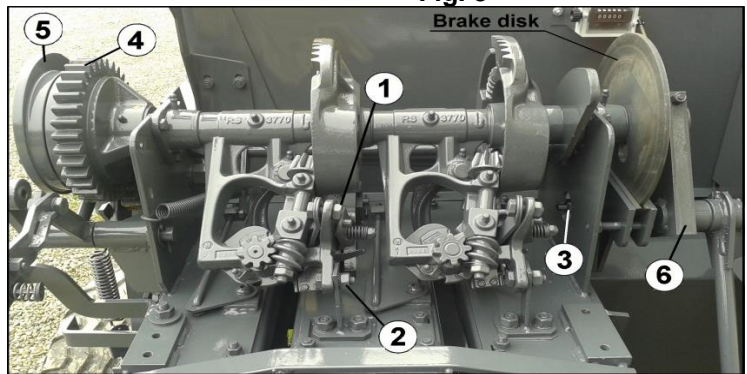

Fig. 9

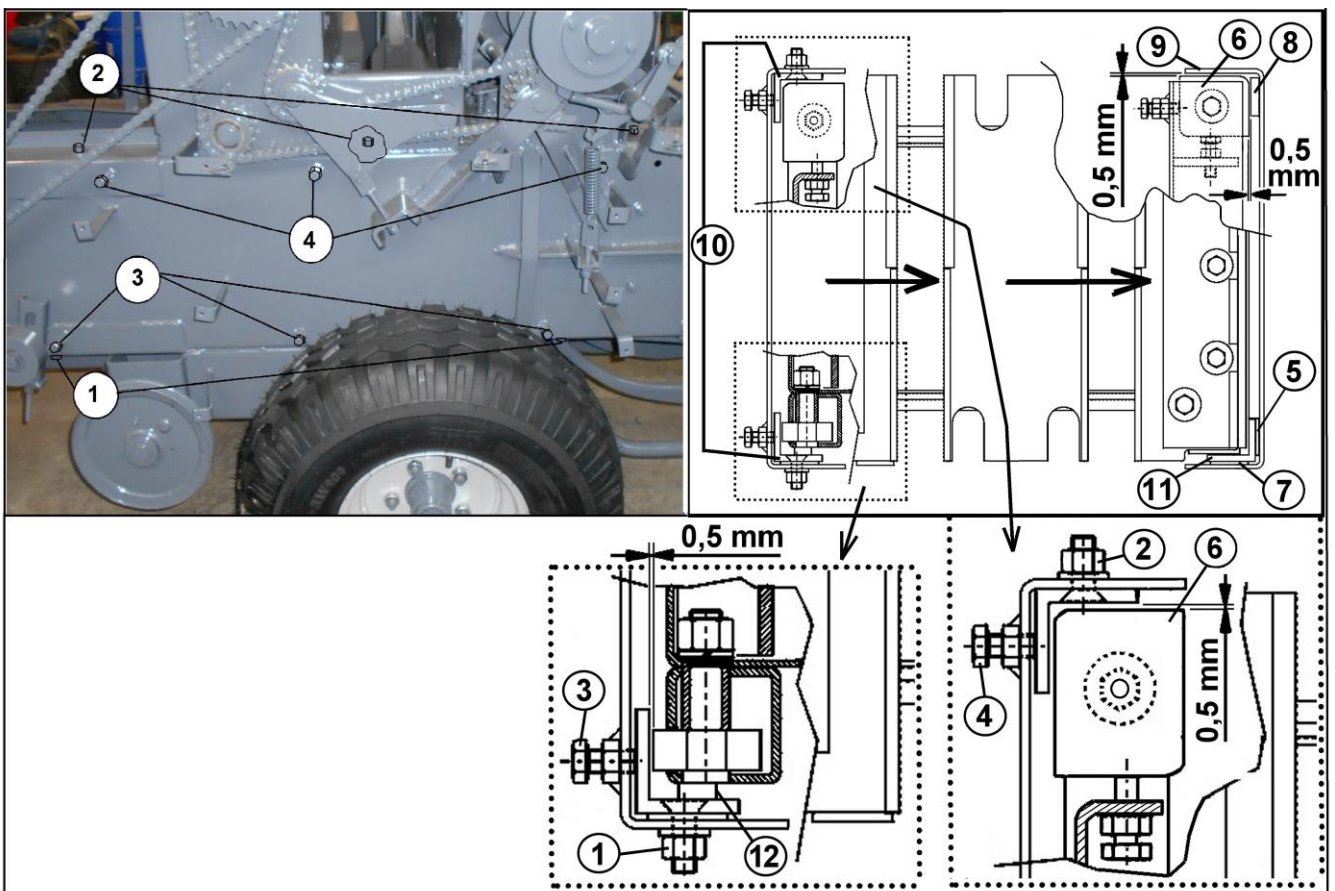

Fig. 12ter

ENGLISH

PLUNGER GUIDES ADJUSTMENT

The piston is set on self-lubricating bearing and is driven by steel blades. In the bale chamber it runs on adjustable steel guides. The lateral adjustment must be made to let the piston have 0.5 mm space where it can move. Despite the minimal clearance space, the piston must not be stopped in its movement. Such adjustment has to be made rarely unless you notice that the piston has too much clearance.

To obtain the correct clearance of the piston, it is necessary to adjust left side piston guides 10 fig. 12ter unscrewing the bolts (no. 1 and no. 2 Fig.12 ter) and then pushing the same guides (first the lower one then the upper one) by the pressure bolts (no.3 and no. 4 Fig. 12ter) until the lateral bearings on the piston have 0.5 mm. or less clearance from the corresponding left side chamber guides. At this point screw again bolts 1 and 2 fig.12ter. The above-mentioned adjustment on the left guides enables to make up for excessive clearance due to the wear on the same left guides and also for the slight clearance caused by a possible limited wear of the right guides.

Once the adjustment of the left side guides has been done, you need to make up for the possible clearance occurring between the upper part of the right superior angular guide and skid 6 fig. 12ter, by moving the mentioned skid by means of the adjustment and fixing screws so that the clearance does not exceed 0.5 mm.

The right inferior angular guide 11 of fig. 12ter is fixed and mounted on the compression chamber by interposing thickening sheets (no. 5 and 7 fig. 12ter). If the right inferior guide appears to be quite worn, you need to dismount the guide and interpose further thickening sheets to compensate.

If, on the contrary, the right inferior guide shows considerable wear and relative clearance, you have to dismount the guide and replace it with a new one interposing original thickening sheets.

The operation on the right inferior guide must be done after dismounting the plunger and before any possible operation on the left guides.

The right superior side guide is fixed and fastened to the compression chamber by screws. The possible excessive clearance occurring between plastic skid 6 fig. 12ter and the mentioned guide is made up for by moving the mentioned skid by means of the adjustment and fixing screws so that the clearance does not exceed 0.5 mm.

You have to operate in the same way to make up for the clearance possibly occurring between skid 6 fig.12ter and its right superior guide (no. 9 fig.12ter).

The adjustment to the plunger height can be made by the eccentric pivots of the 4 supporting bearings n°12 fig. 12ter, after pulling out the piston from the bale chamber.

In case the rails where the piston runs are obstructed by loam or by other materials, it is necessary to pull the piston out of the bale chamber, clean the same rails or, if necessary, disassemble the rails, clean them and re-assemble them.

PICK-UP

This component collects the material to be baled and conveys it to the feed forks. As a result, a certain number of spring-loaded teeth pass over the ground and after lifting the material to the maximum height determined by their rotation, they retract with a movement defined by a special cam.

When the machine is working on uneven ground, the spring-loaded teeth may bend or break. To replace them, disassemble the plates of the pick-up casing. It is important to try to straighten any spring-loaded teeth which may have been bent during use and to replace the broken ones and those that cannot be straightened. For the adjustment of the pick-up see page 10.

TWINE BINDING DEVICE

FUNCTIONING OF THE TWINE KNOTTERS

The head of the forming bale makes the twine move forward by itself. The twine - held at one end by the cord holder disc (no. 1 Fig. 15 / no. 5 fig.18 bis p.26) - is drawn out of the little box where the rolls are by the advancing bale. When it reaches a certain length, the arch lever (no.1 Fig. 4) is brought by the advancement of the bale to its maximum height starting the binding device.

In such conditions the bell gear (n° 10 Fig. 15), with its rotation at the right moment of the phase, makes the binding process start as follows:

1. The needles, moved by the drive crank (no. 12 Fig. 15), bring the twine to the knotters.
2. During step 1, when the needles come out from the superior part of the bale chamber, crescents (no. 2 Fig.15 / no. 3 fig. 20bis) moved by the cam (no. 3 Fig. 15) catch the twine and take it to the knotter hooks (n° 13 fig. 15 / n° 5 fig. 18 ter p.26).
3. The knotter hooks moved by the semi-toothed gears (no. 5 Fig. 15) catch the twine end brought by the crescents and the twine end held by the cord holder disc and tie them.
4. In the meantime, the superior ends of the twines brought by the needles have been put into the notches (no. 11 Fig. 15 / no. 6 fig.18 bis p.26) of the cord holder disc and have been held by the same cord holder disc.

The movement is transmitted to the cord holder disc by the semi-toothed gears (no. 5 Fig. 15) through both gears (no.6 and no.7 Fig. 15).

5. At this point, the ejector and knife holder arms (no. 8 Fig. 15 / no. 2 fig.19 p.25) - quickly moved by the *purpose made* cams in the inner central part of the semi-toothed gears – cut the twine ends beyond the knot and eject the knots from the knotter hooks.
6. The needles, which are always moved by the drive crank (no. 12 Fig. 15), are moved back to the stand-by position.

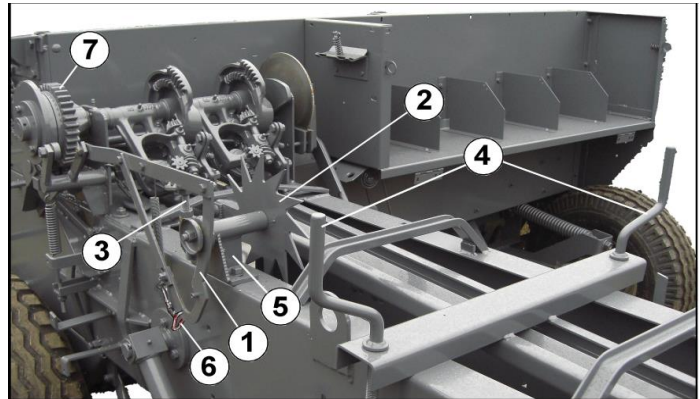

Fig. 4

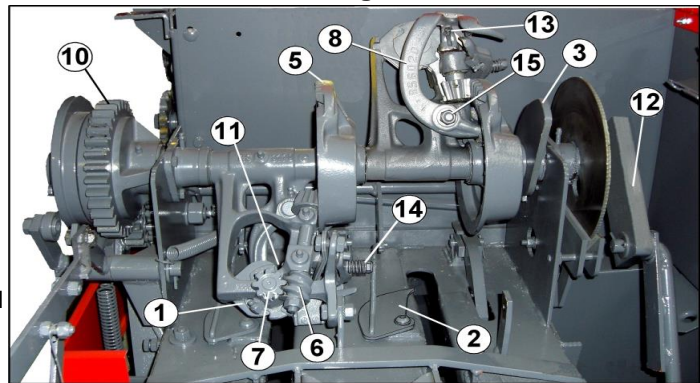

Fig. 15

ATTENTION! In order to understand how the binding device runs, we suggest doing a tie with the baler turning very slowly.

ADJUSTMENT OF THE NEEDLES

The adjustment is made with screws 1 and 2 (Fig. 11).

To reduce the distance of the needles ends from the cord holder disc while taking the twine to the knotter, you have to loosen screw 2 a fraction of a turn and to tighten screw 1 a fraction of a turn.

To increase such a distance do the opposite procedure.

To move laterally, bend the needles as necessary.

To obtain a precise adjustment, refer to the measurements indicated below:

1. Adjustment of needle transverse position.

The distance between the knotter frame and the needle lateral side must be from 0,5 mm to 1 mm (fig.17), that is the needle must rub the binder frame (fig.17).

Usually this adjustment is carried out with the needle arm in idle condition, by bending the needle itself.

2. Adjustment of needle height.

When the needles are at their upper stroke end, the distance between the lower side of the needle and the bottom of the notch of the cord holder disc must be 18/22 mm (fig.17).

Usually this adjustment is carried out with the needle arm in idle condition, by loosening or tightening screws 1 and 2 fig.11.

3. Adjustment of needle advancement.

When the needles reach the end of their course (needle upper stroke end – fig.18).

The distance between the cord holder disc and the needle tip roller center must be min. 80 mm, max. 85 mm.

To carry out this adjustment, use the needle arm adjustable fork connection (n° 3 fig.2).

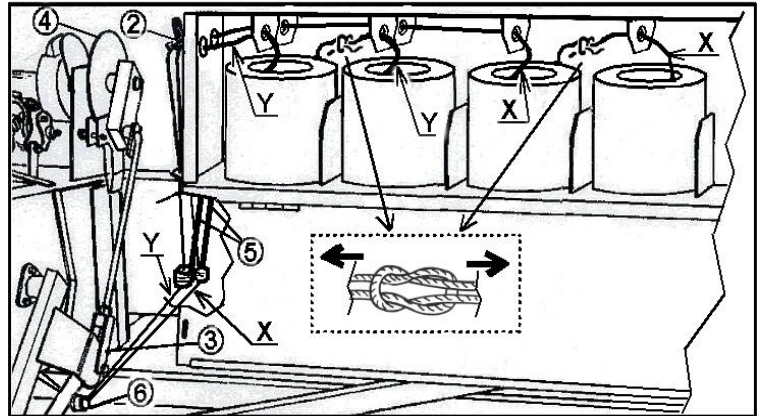

Fig. 2

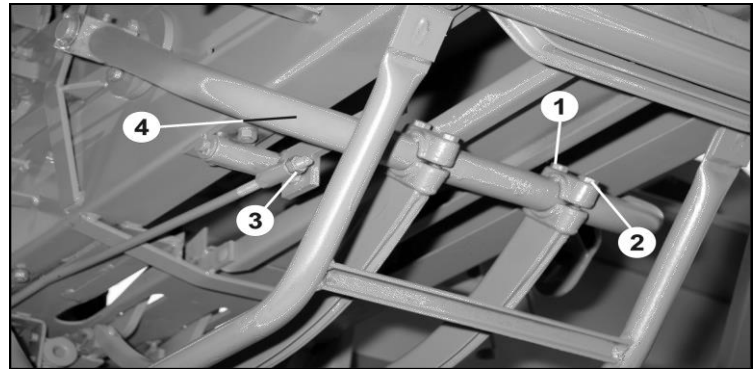

Fig. 11

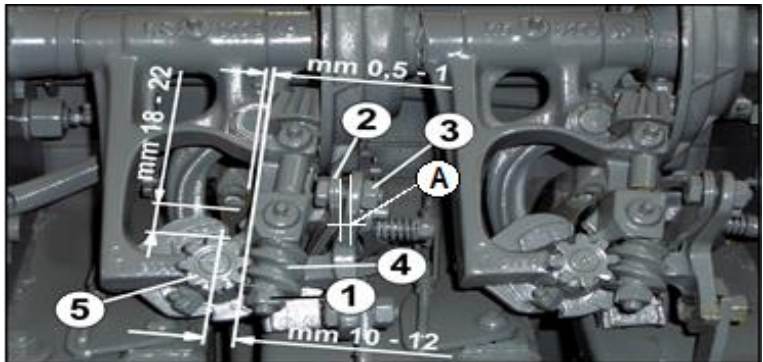

Fig. 17

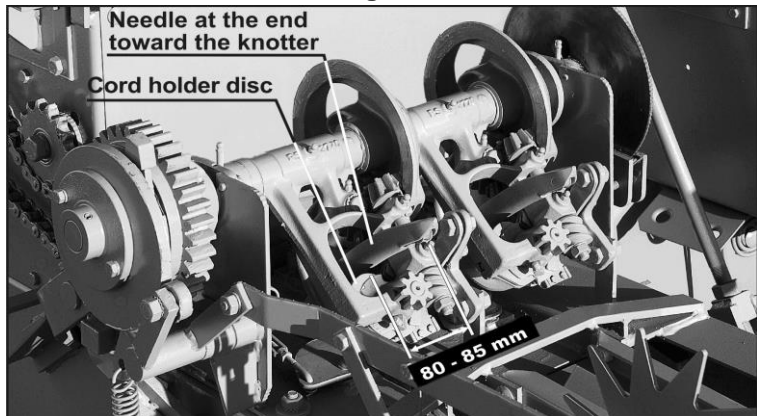

Fig. 18

ADJUSTMENT OF THE TWINE GUIDE CAMS (CRESCENTS)

The clearance between the twine guide cams and their pivots must be the minimum allowing them to move freely.

In the rest position, the twine guide cams must have their tips in line with the edge of the passage holes of the wire brought by the needles, with a maximum tolerance of 2 mm towards the inside (fig. 20bis/B).

For this adjustment, screw or unscrew as required clock n.4 of figure 20bis/B after having removed the cotter pin n.5 of figure 20bis/B.

Being the needle arm in idle, during the raising movement of the needle, the minimum distance between the tip of the twine guide cam and the inner side of the needle must be 2÷3 mm (fig.20 bis/A).

If the adjustment of needle height, carried out as shown on p.24 paragraph 2, should not allow to respect the above mentioned crescents distances, you will have to correct the previous adjustment of the needle height.

ADJUSTMENT OF EJECTOR AND KNIFE HOLDING ARMS

The ejector and knife holding arms (no. 8 Fig. 15) must cut the excess twine and take the knots off the knotter hooks.

The knife adjustment does not exist. It is only necessary to keep the knife well-sharpened or to replace it.

The ejector arms adjustment, on the contrary, is very important and must satisfy the following requirements:

1. the ejector tongue (no.1 Fig. 20) in its movement must rub with light pressure on the back of the knotter hook (no. 2 Fig. 20).
2. The tongue is curved to follow the back of the knotter hook. The tongue curve must be centered with the back of the above - mentioned hook.
3. The tongue, in its ejection movement, must go beyond the hook end not less than 6 mm. and not more than 12 mm. (Fig. 19).

To check the adjustment of the ejector arms and sharpen the knives, take the bolts (n. 2 , Fig. 9) off the knotter group you are dealing with and lift it to the top as shown in Fig. 15.

This operation must be done with the needles in the rest position.

When the knotter group is lifted, the ejector arm follows its own movement and the adjustment control becomes easy.

To make adjustment 1 and 2, bend the ejector arm into the desired direction. For adjustments 1 and 2, it isn't necessary to dismount the ejector arm nut (no. 15 Fig. 15 / no. 3 fig.19).

In case the parameters shown in par. 3 are not found, because of wear or bumps, you have to replace reel 1 fig.19 mounted on the ejector arm or replace the ejector arm fully or, after disassembling the entire knotter, repair or replace the cam with the binder control disc (n.5 fig.15).

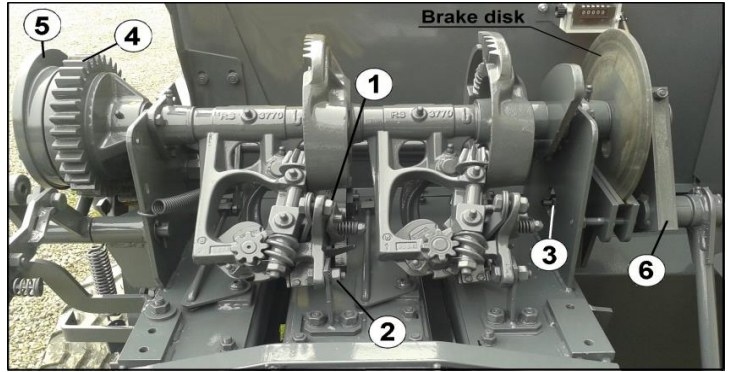

Fig. 9

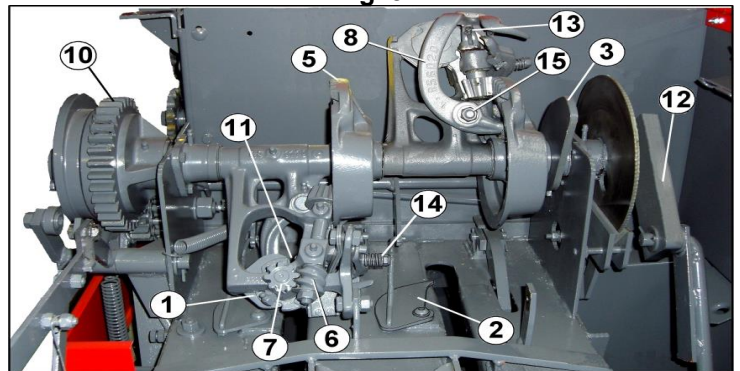

Fig.15

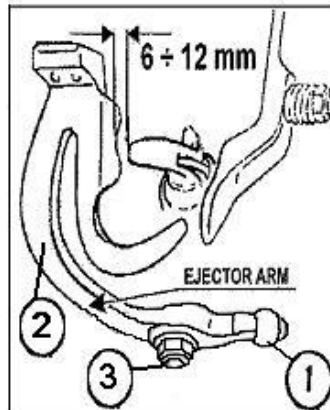

Fig.19

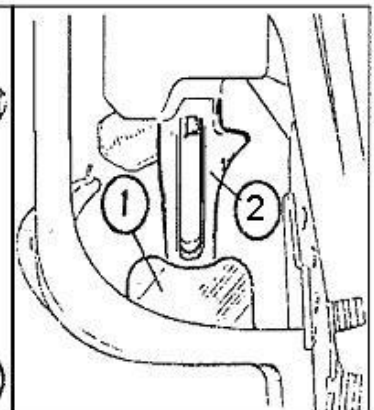

Fig. 20

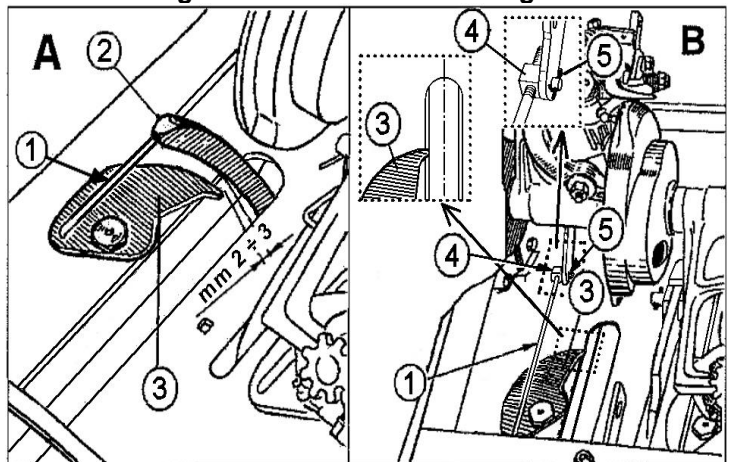

Fig. 20 bis

ADJUSTEMENT OF CORD HOLDER DISC POSITION

The cord holder disc position must be adjusted so that the twine brought up by the needle is caught in its notches (no. 11 Fig.15 / Fig. 17 / no. 6 fig. 18 bis). The adjustment must be done so that, being the needles in their rest position, the distance between the knotter support/frame and the left edge of the notch of the cord holder disc is between 10 and 12 mm. see fig.17.

In these conditions, after performing at least two bindings, cord holder 4 fig.18bis must have slightly penetrated the notch of the cord holder disc.

To make this adjustment do as follows:

1. Loosen nut 1 Fig. 17 about 3mm,
2. With a hammer give a sharp blow on the nut in the direction of the pivot where it moves in order to disconnect the screw gear (no. 4 Fig. 17) which is fixed by a taper.
3. Set the cord holder disc in the position described above and shown in Fig. 17.
4. Turn the screw gear (n. 4 Fig.17) counter-clockwise until it touches the gear (no. 5 Fig. 17), to eliminate any clearance in the adjustment.
5. Block gear 4 fig.17 in such a position on its tapering axis by screwing up again nut 1 fig.17.

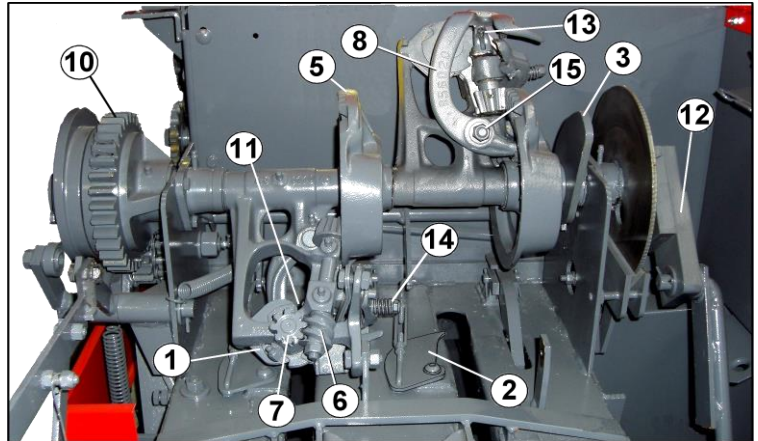

Fig. 15

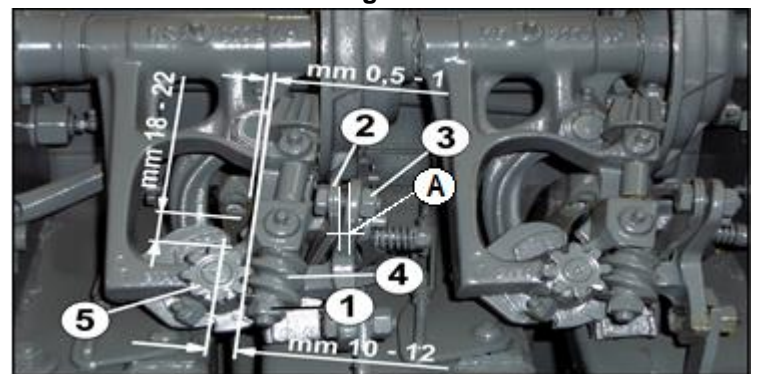

Fig. 17

ADJUSTMENT OF THE PRESSURE ON THE CORD HOLDER DISC

The pressure on the cord holder discs must hold the twine made taut by the proceeding bale but, at the same time, it must allow the knotter hooks to pull out the necessary amount of twine for the formation of knots.

The pressure adjustment is made by adjusting flat spring 1 Fig. 18bis. To do this, turn screw 2 Fig. 18bis after loosening lock nut 3 Fig. 18bis.

To find the right pressure of the cord holder disc, operate as follows: the twine must be inserted and pressed into the cord holder disc. Adjust the spring 1 in figure 18 bis as described above, so that the twine only runs when subjected to a force F of between 40 and 60 kg. This corresponds with a distance A of around $2 \div 3$ mm (see fig.18 bis and fig.17).

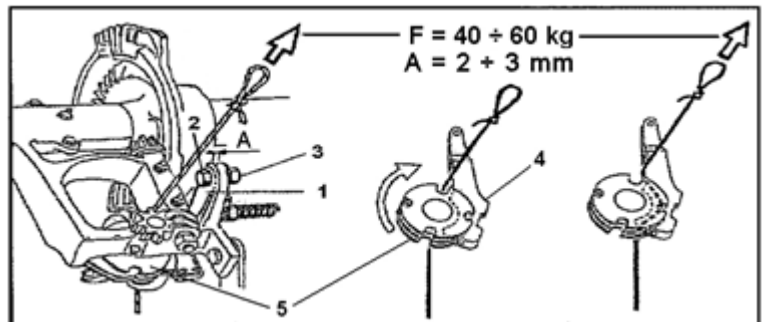

Fig. 18 bis

ADJUSTMENT OF THE TONGUE OF THE KNOTTER HOOK.

With the knotter in the rest position (I.E. with the needles in the rest position), the hook tongue (1 Fig. 18ter) must be open under a force between 5 and 10 kg. If necessary, tighten or loosen spring 2 Fig. 18 ter.

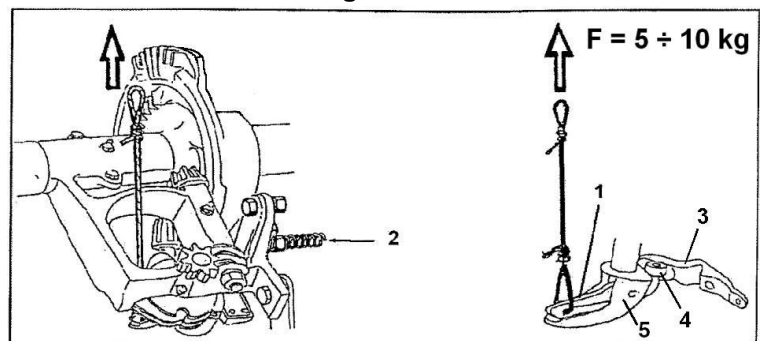

Fig. 18 ter

ATTENTION!

The twine binding device chamber must be blown with a high pressure air unit and cleaned at least once a day to avoid blockage of parts that can prevent the correct functioning of the binder (e.g. crescents control shaft, straw-stopper etc.)

WARNING!

If the binding unit is uncovered during use, due to functional reasons, the operator must be very careful to avoid all possible risks.

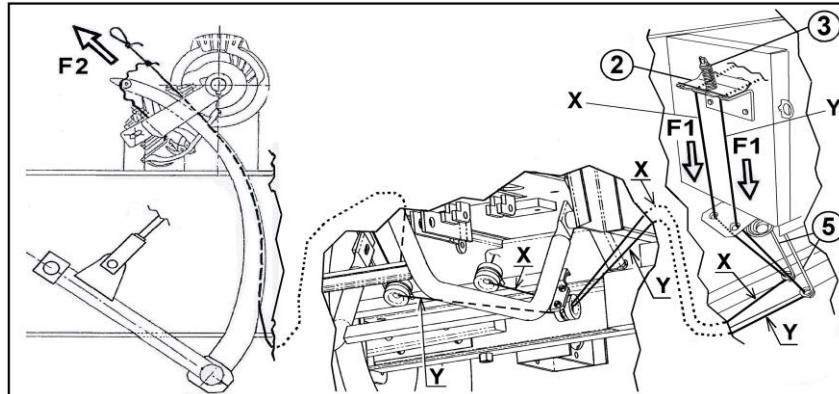

Fig. 4 bis

MALFUNCTIONING OF THE TWINE BINDING DEVICE

Some binding faults may come from wrong use of the baler, for example:

1. Too fast or too slow pace of the baler
2. Excessive or insufficient compression of the crop
3. Irregular feeding or too moist or too dry crop
4. Irregular section of the binding twine.



Besides with the wear and tear, some baler parts completely independent from the knotters can disturb their functioning. The points to check are the following:

1. Inaccurate twine tension – roughly speaking, on coming out of the twine box, the twine should slide through clamps 2 Fig. 4 bis under a force F_1 of about 1-2 Kg. or it should slide along its path under a force F_2 between 10 and 14 Kg. (Fig. 4 bis). If necessary, adjust the pressure of the above mentioned clamps (no.2 fig. 4 bis) by means of tightening or loosening spring 3 fig. 4 bis and, if necessary, springs 5 fig. 4 bis.
2. Wrong knotter/needles positioning
3. Uneasy sliding of the twine due to possible blockage of the small rollers of the needles, tangling of the twine or wearing of twine passages.

Therefore we suggest the following:

1. First check all the adjustment parameters for twine binding device as shown in the present book
2. Then make the adjustment carefully: don't turn the nuts over $1/3$ or $1/2$ when you tighten the tongues of the knotter hooks and the cord holder discs.
3. Finally the shape of the knot helps to detect the cause of the binding faults, therefore in the following table you can see the main problems and their solutions:

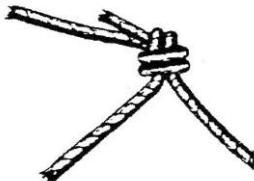
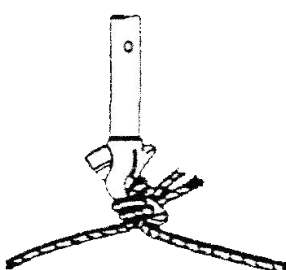
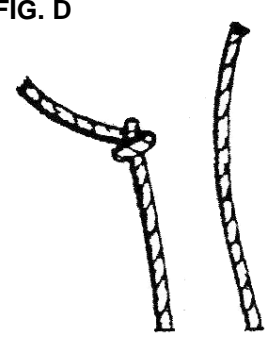
	Problem	Cause	Solution
<p>FIG. A</p>	Correct knot with 2 clean cut ends and no loop.		
<p>FIG. A bis</p>	Knot with loop.	<p>The twine slips too much in the holder/twine pusher.</p> <p>The knife is not cutting properly.</p>	<p>Tighten the flat spring in the twine holder/pusher finger – see Fig.18 bis, page 26.</p> <p>Sharpen or replace the knife. Check that the ejector arm is correctly adjusted – see paragraphs.1, 2 and 3 on</p>

		page 25.	
	Problem	Cause	Solution
FIG. B 	The twine ends of the knot are of different lengths.	The knife is worn. Insufficient pressure of cord holder finger 4 Fig. 18bis on its cord holder disc. The bales are too loose.	Sharpen the knife or, if necessary, replace it. Tighten flat spring 1 Fig. 18bis Increase the pressure of the bale by rotating handles 4 Fig. 4.
FIG. C 	The knots don't slide out of the knotted hook.	Ejector tongue 1 Fig. 20 of ejector and knife-holding arm 8 Fig.15 works too far from the back of knotted hook 2 Fig. 20. Ejector and knife – holding arm 8 Fig. 15 doesn't move enough and doesn't overcome correctly knotted hook 2 Fig. 20. Excessive pressure on tongue 1 fig.18ter of the knotted hook. The knotted hook is worn. There is too much pressure in the bales.	Bend the ejector and knife holding arm until the ejector tongue rubs the back of the knotted hook. Replace the roller of the ejector and knife holding arm if it is worn. Otherwise operate as shown on p. 25 par.3. Loosen the pressure acting on spring 2 fig.18ter. Replace the knotted hook. Decrease the pressure of the bale by rotating handles 4 Fig. 4.
FIG. D 	Only the front twine knots. (front twine = twine held by the cord holder disc 5 fig. 18bis).	The twine is wrongly threaded. The crescent/twine guide cam (3 Fig. 20 bis) doesn't return to its correct rest position. The knife holding arm is deformed and doesn't bring the twine to the groove of the knotted hook.	Check the threading of the twine. Check the adjustment and movement of the crescent as shown on p.25 fig.20 bis. Replace the deformed part.
FIG. E 	Only the back twine knots. (Back twine = twine brought by the needle)	The twine holder disc catches only one twine. The tongue and the roller of the knotted hook are deformed or worn.	Increase the pressure on the cord holder finger 4 Fig. 18bis. Replace these parts.
FIG. F 	The twines are not cut or are broken after the knot.	The ejector arm is too close and not perfectly centred on the back of the knotted hook.	The ejector arm must rub slightly and uniformly and be centred on the back of the knotted hook. (see fig. 20 and paragraphs 1 and 2 of p.25)

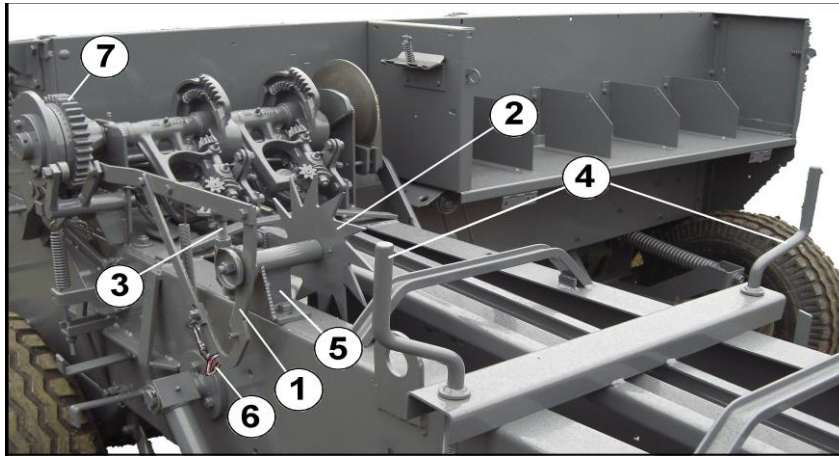

Fig.4

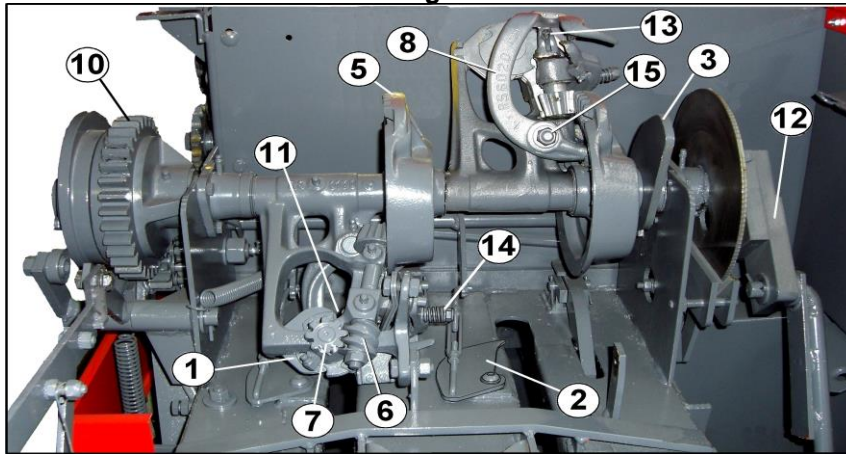

Fig.15

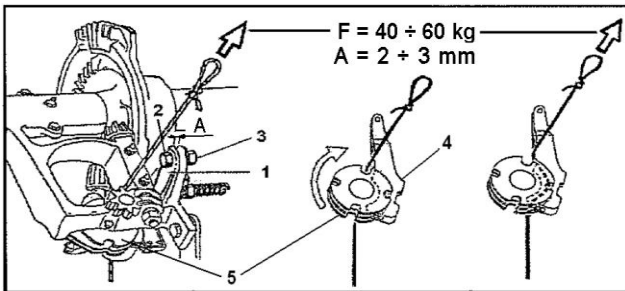

Fig. 18 bis

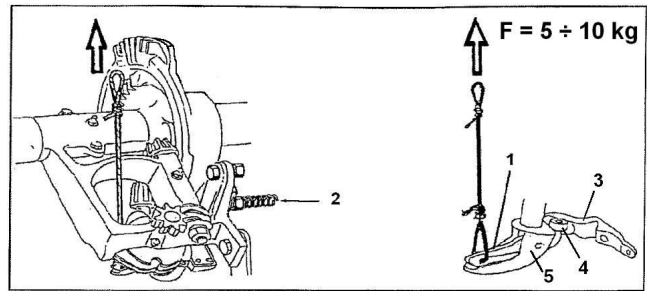

Fig.18 ter

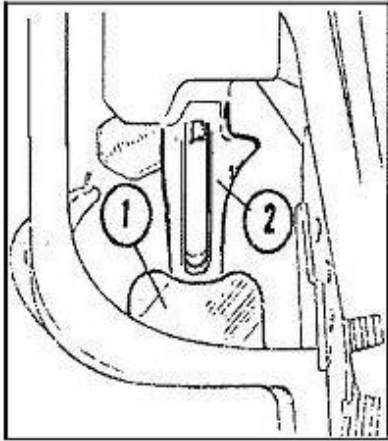

Fig. 20

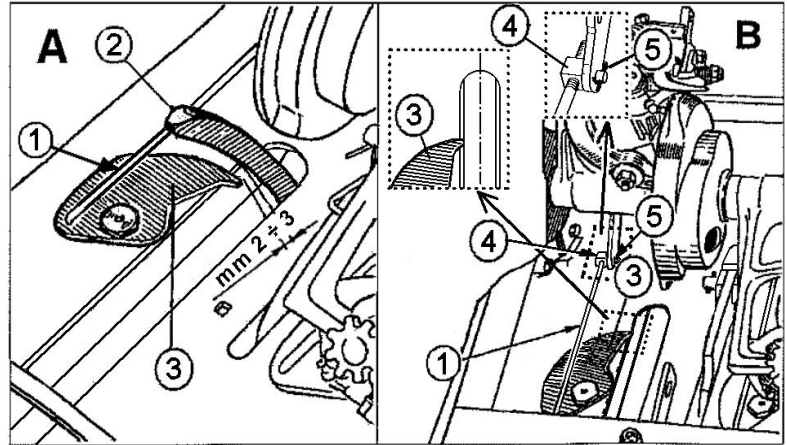

Fig. 20 bis

IRON WIRE BINDING DEVICE

MOUNTING THE IRON WIRE

1. Insert the coiled, annealed and oiled baling wire coils size n° 12 for pick-up balers into the special containers (Fig. 21).
Make sure that the coils are positioned so that by pulling the central end of the wire it unwinds counterclockwise to prevent the wire from becoming tangled.
2. Thread the wire as indicated in Fig. 21-22.
3. Tie the ends of the wire to the bottom cross member (bar) of the baling chamber (Fig. 22).
4. Completely lift lever 1 shown in Fig. 4/ter by turning metric wheel 2 in Fig. 4/ter to engage the binder.
5. Turn the flywheel counter-clockwise until the needles are in their rest position - (the needle arm must be in the rest position - needles retracted). In this way, the iron wire unwound from the coil and brought by the needle to the binder is held by the holder/cutter knife and the machine is ready to start its work.
6. At this point, a "piece" of wire has been formed, which is tied at one end to the bottom cross member and cut at the other end by the holder/cutter knife. This "piece" of wire can be removed by being slipped off the binder, after being "untied" from the bottom cross member.

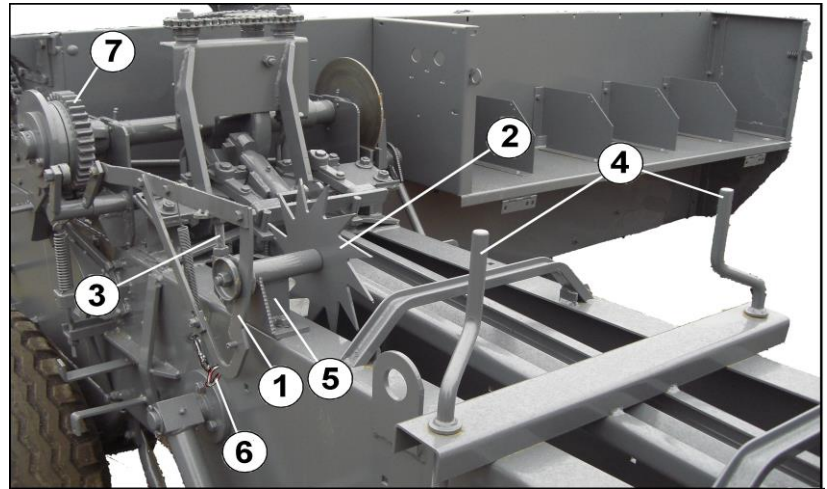

Fig. 4 / ter

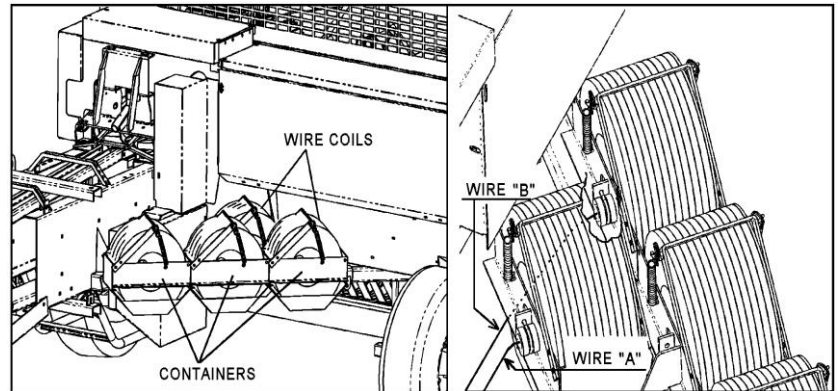

Fig. 21

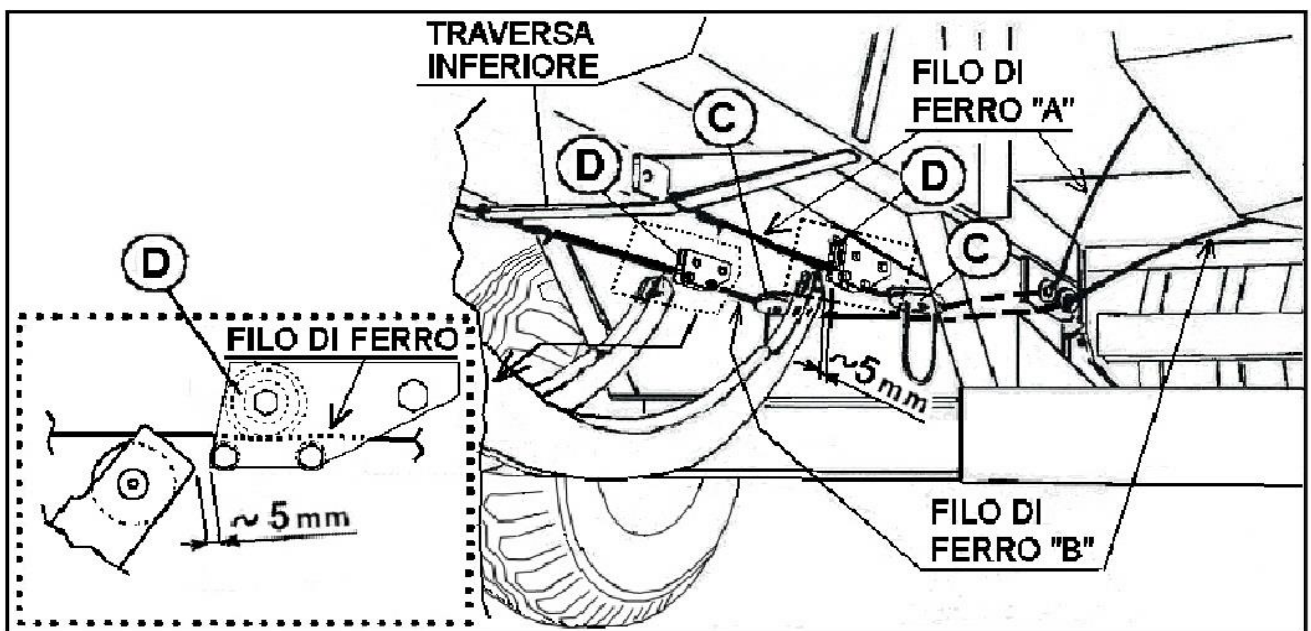

Fig.22

FUNCTIONING OF THE IRON WIRE TWISTERS

The head of the bale that has formed advances along with the wire, which is held at one end by the squared wire holder cutters (Fig. 24): this wire is unwound from the containers that house the coils.

When the bale has reached the chosen length, the sector lever (n° 1 Fig. 4) is moved upward to the maximum height by the advancement of the bale, thus engaging the binder. Under these conditions, the bell gear (n° 10 Fig. 15/ter), with its rotation at the point determined by the timing, starts the rotation of the binder shaft and initiates the binding cycle that proceeds as follows:

1. The needles, driven by the drive crank (n. 12, fig. 15/ter), take the wire to the binder unit.
2. During step 1, the needles leave the top side of the compression chamber and take the wire to the twister hooks (kinking tips) and to the wire holder cutters - (Fig. 24).

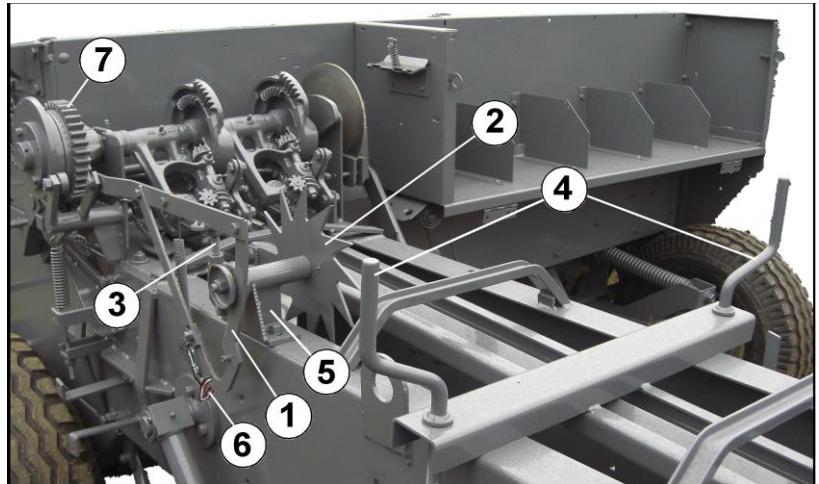

Fig. 4

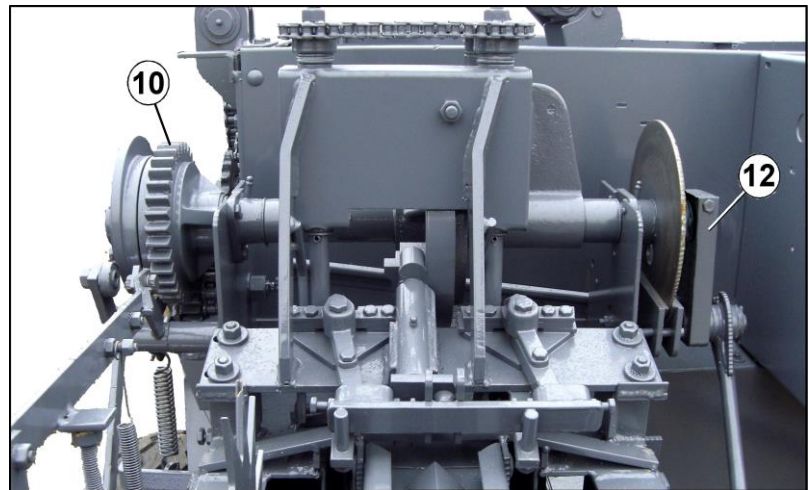

Fig. 15 / ter

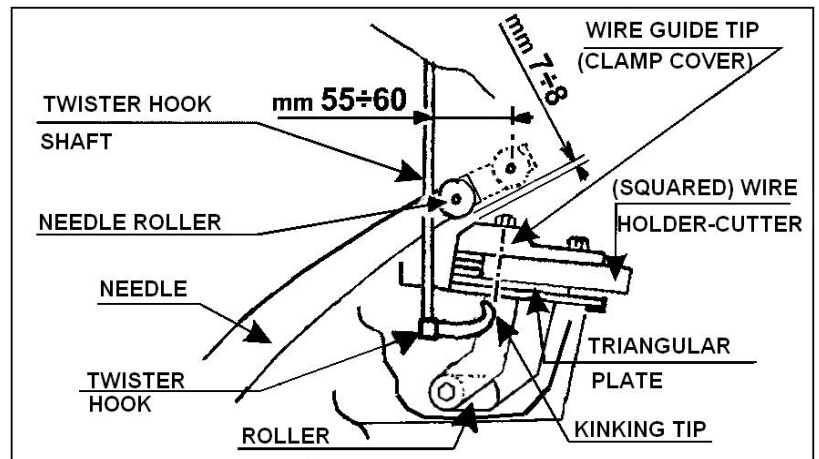

Fig. 24

3. The twister hook tips, which are made to rotate by the semi-toothed gear (n° 4 Fig. 23), grab the (wire) ends brought by the needles and the (wire) ends already held by the wire holder cutters and twist them together.
4. At this point, the wire holder cutters, being moved rapidly by the special cams, cut the ends of the wire past the twisting point. The twisted wire is unthreaded by the pulling action of the material itself. One end of the wire is held by the wire holder cutters for the next binding cycle.
5. The needles, which are always driven by the drive crank (n° 12 Fig.15/ter), return to the rest position.

ATTENTION!

To understand how the iron wire binding device works, it is recommended to perform a binding cycle turning the machine very slowly.

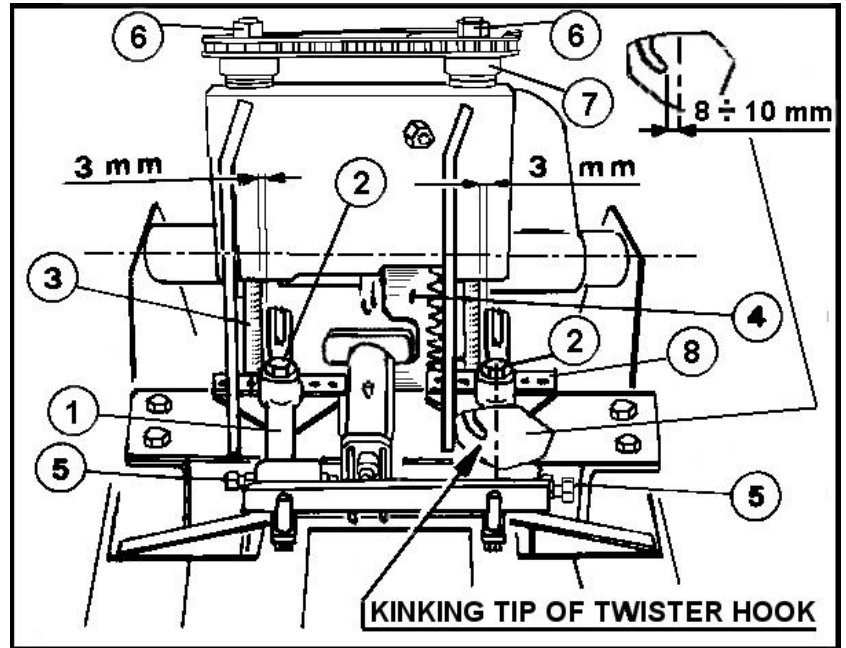

Fig. 23

ADJUSTMENT OF THE NEEDLES

The needles are adjusted by using screws 1 and 2 as shown in Fig. 11.

To reduce the distance of the needle ends from the wire guide tips (Fig. 24), when they take the wire to the binder, loosen screw 2 a fraction of a turn and tighten screw 1 by the same amount (fig.11).

To increase the above mentioned distance, do the opposite procedure.

To move laterally, bend the needles as necessary.

To obtain a precise adjustment, refer to the measurements indicated below:

1. adjustment of needle transverse position.

The distance of the lateral side of the needles from the twister hook shaft (n°3 fig.23) must be about 3 mm (Fig. 23).

At the same time, the centre of the needles must correspond to the centre of rotation (no. 2 Fig. 23) of the wire holder cutters.

Usually this adjustment is carried out with the needle arm in idle condition, by bending the needle itself.

2. adjustment of needle height.

The bottom side of the needle roller (Fig. 24) must be 7-8 mm. from the wire guide tip when the square knife (wire holder cutter) is at the half way point of its rotation (Fig. 24). Usually this adjustment is carried out with the needle arm in idle condition, by loosening or tightening screws 1 and 2 fig.11.

3. adjustment of needle advancement.

When the needles reach the end of their course, the distance between the centre of the needle roller and the twister hook shaft must be 55-60 mm (Fig. 24). To carry out this adjustment use the needle arm adjustable fork connection (n° 3 Fig. 22 bis).



Fig. 22 bis

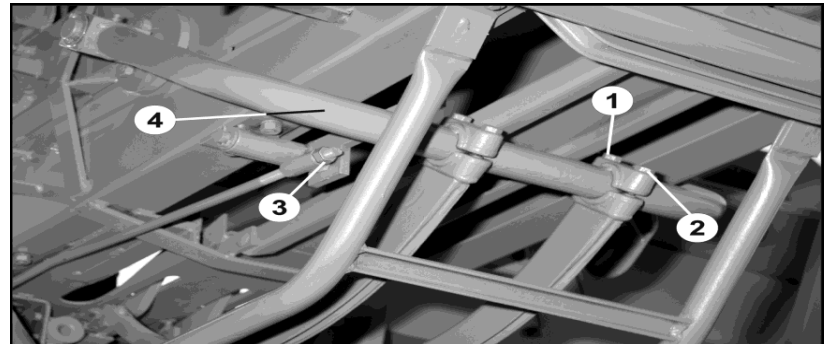

Fig. 11

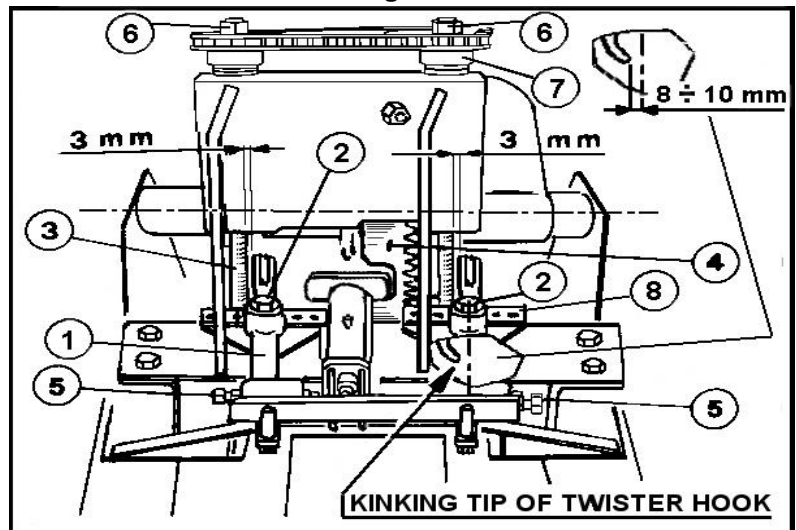

Fig. 23

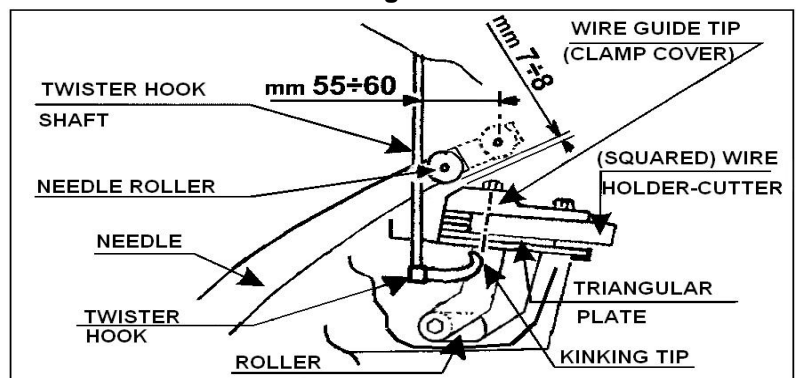

Fig. 24

ADJUSTMENT OF THE WIRE HOLDER CUTTER

Use screws (n° 5 Fig. 23) to adjust the wire cutting holding action of the wire holder cutter knives (n° 1 Fig. 23).

If the adjustment is properly done, the wire must have a 3 mm “flattening” where it is held (see Fig. 23bis). A shorter “flattening” can cause the wire to be released, a longer “flattening” can cause nut/pivot 2 fig. 23 to get broken.

ATTENTION!

To ensure a correct wire binding operation, make sure that the wire roller pulleys (the rollers under the wire holder/cutter knife included – fig. 24) are not blocked and that the wire guide bushes are not worn to avoid excessive wire sliding resistance during binding.

ADJUSTMENT OF THE PHASE OF THE TWISTER HOOK

As the needles are in a rest position, the tip of the twister hook (see figure 24) must be 8÷10 mm “more to the left of the rotation pin” (n.2 – fig.23)” of the square knife to cut/stop wire (see figure 23) or, rather, it must be “more to the left by 8÷10 mm of the vertical plane containing the axis of rotation of the square knife to cut/stop wire (n.2 – fig.23 and fig.24).

To perform the above adjustment loosen nut 6 fig.23; with a plastic hammer give a sharp blow on the twister hook shaft following the direction of its axis (n°3 fig.23) in order to free the shaft itself from its tapering connection with gear 7 fig.23.

Then set the shaft and its twister hook in the above mentioned position and re-block the tapering connection between the twister hook shaft and its gear (n°7 fig.23) by means of nut 6 fig.23.

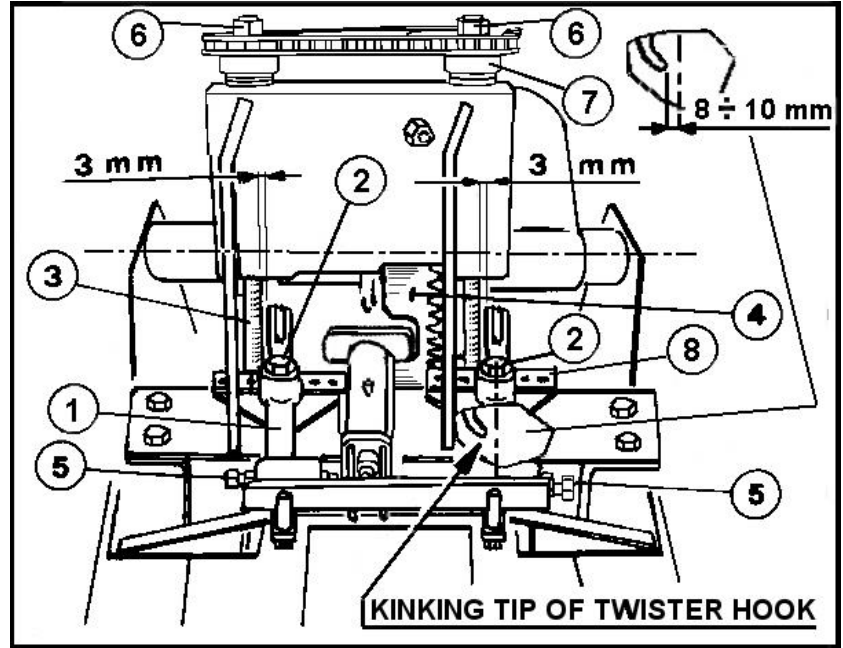

Fig. 23

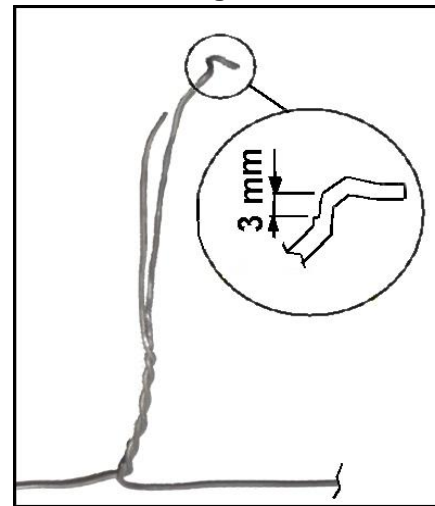

Fig.23 bis

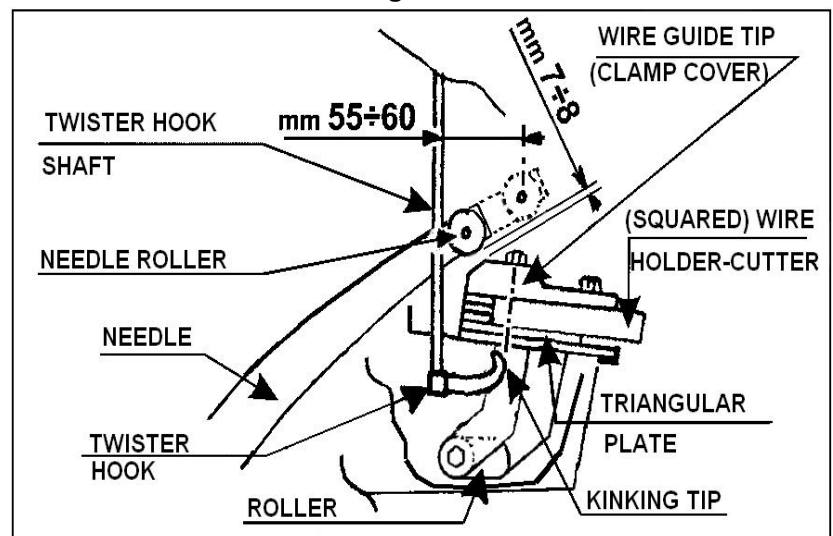
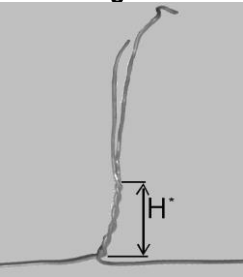
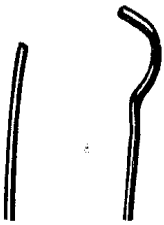



Fig. 24

MALFUNCTIONING OF THE WIRE BINDING DEVICE





Many and various can be the causes determining binding problems. Some of these causes have nothing to do with the binder itself. Therefore we suggest the following:

1. Make sure that the feeding of the baler is regular, avoiding too big "feeding shares" and, therefore, take the piston strokes per minute at $85 \div 90$.
Make sure that the bale compression is neither excessive nor too low.
2. Make sure that the phasing of the synchronized movements of the baler is the one prescribed (see "Phase" p. 17 of this Use and Maintenance Handbook)
3. Make sure that the iron wire used is the one prescribed, be it coiled, annealed and oiled iron wire size n° 12 (corresponding to a diameter of the wire of 1.8 mm)
4. Make sure that all the wire passages, including the needle sheaves and the rollers under the wire holder/cutter knives, are not worn or blocked and, therefore, allow a free passage of the wire.
5. Make sure that all the adjustment parameters of all the parts of the binder are respected in accordance with this Use and Maintenance Handbook.
6. Finally, the observation of the conditions, in which you find the iron wires when they don't bind, helps you to detect the cause of the binding faults; therefore, in the following table you can see the main problems and their solutions:

	Problem	Cause	Solution
<p>Fig. A</p> 	<p>Correctly twisted and held iron wires.</p> <p>One wire end is cut, the other is cut and bent without showing any shining marks left by the holder/cutter knives.</p> <p>The twisted plait length H is about 4.5 cm.</p>		
<p>Fig. B</p> 	<p>The wires are not twisted together, one end is clean cut, the other is bent and cut.</p>	<p>The wire doesn't go easily on its course.</p> <p>The wire brought up by the needle is pushed far from the twister due to the return crop to be pressed in the compression chamber. Too much crop is fed on each stroke because the number of strokes per minute is insufficient.</p>	<p>Clean and lubricate all the guides and passages of the wire and, if necessary, replace them (fig.22).</p> <p>Increase the plunger strokes per minute to $85 \div 90$.</p>
<p>Fig. C</p> 	<p>The twisting is insufficient: it is too short and gets unravelled under tension.</p>	<p>The wire is rusty, already corroded and not oiled.</p>	<p>Remove any wire scraps from the twister hook.</p> <p>Oil the wire, in case replace it.</p>
<p>Fig. D</p> 	<p>The wires are not twisted together, one end is clean cut, the other is bent but straight and shows shining marks left by the holder/cutter knives.</p>	<p>The wire is not perfectly held by the wire holder/cutter knives.</p> <p>The wire is of insufficient</p>	<p>Adjust the wire holder/cutter knives increasing the pressure on the wire (see p. 34, 5 Fig. 23 and Fig. 24). If worn, replace the central plate of the group of 3 plates (n°8 Fig.23) and in case the wire holder/cutter knife.</p> <p>Use wire n° 12 - diameter 1.8</p>

		diameter.	mm.
--	--	-----------	-----

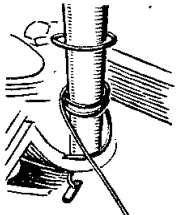
* Length H verified with the machine working without crop.

<p>Fig. E</p> 	<p>One wire is broken at the beginning of the twisted plait.</p>	<p>The wire doesn't go easily through its passages.</p> <p>The movement of the twister hook is in advance.</p> <p>"Crude", not annealed wire.</p> <p>The wire is of insufficient diameter.</p>	<p>Check and lubricate the wire passages (Fig. 21 and 22 see also p.30).</p> <p>Slow down the twister hook turning it counter-clockwise (see p.34 and Fig. 23 and 24).</p> <p>Change the iron wire.</p> <p>Use wire n° 12 - diameter 1.8 mm.</p>
<p>Fig. F</p> 	<p>The bale comes out of the compression chamber without any wires on one or both sides because the needle doesn't bring the wire to the binder.</p>	<p>The needle is laterally bent.</p> <p>The guiding pulleys are not in their correct position.</p>	<p>Check the prescribed 3mm distance of the needle side from the twister hook shaft (see p.33 Fig.23).</p> <p>Align the plates of pulleys C and D under the compression chamber with the needles sheaves (rollers) (fig.22).</p>
<p>Fig. G</p> 	<p>The wire is twisted around the twister hook shaft. The bale comes out of the compression chamber without any wire around.</p>	<p>The wire isn't caught by the holder/cutter knife, so it isn't cut.</p> <p>The needle advancement is too low.</p> <p>The needle isn't in its correct side/lateral position.</p> <p>The twisting is completely out of phase, either highly advanced or highly delayed.</p>	<p>Check the prescribed position of the needle (see p. 33 Fig. 23 and 24).</p> <p>Check the prescribed 3mm distance of the needle side from the twister hook shaft (see p.33 Fig.23).</p> <p>Adjust the phasing of the twister hook. Check the correct position of the needle (see p. 34 and Fig. 23/24).</p>
<p>Fig. H</p> 	<p>The wires are not twisted. The end of one wire is clean cut, the end of the other wire has got thinner and has then broken. The wire has been broken before being twisted.</p>	<p>The wire coil is tangled and cannot pass through its passages.</p> <p>The wire is of insufficient diameter.</p> <p>Rusty or not oiled wire.</p> <p>The wire doesn't go easily along its course.</p> <p>The crops to be baled are too moist.</p> <p>The wire has sprung off its</p>	<p>Set up the coil and feed the wire into the binding device again (fig. 21 and 22 – see also p.30).</p> <p>Use wire n° 12 - diameter 1.8mm.</p> <p>Oil the wire, clean and lubricate all the guides and wire passages. If necessary, replace them (fig. 21 and 22).</p> <p>Clean and lubricate all the guides and wire passages. If necessary replace them (fig. 21 and 22).</p> <p>Reduce the pressure in the compression chamber and make the bales shorter (p.20).</p> <p>Straighten the guiding pivots</p>

WHEEL MOUNTED BEHIND THE PICKUP

The baler is equipped with a suitable bracket (no.1 Fig. 25) behind the pickup, to which the wheel (no. 2 Fig. 25) can be fixed, after it has been pulled out together with its hub from its original seat, (no. 2 Fig. 26). By this way, you reduce the overall width of the baler by about 20 cm. for a total with of 235 cm, (see insert "A" of fig. 25).

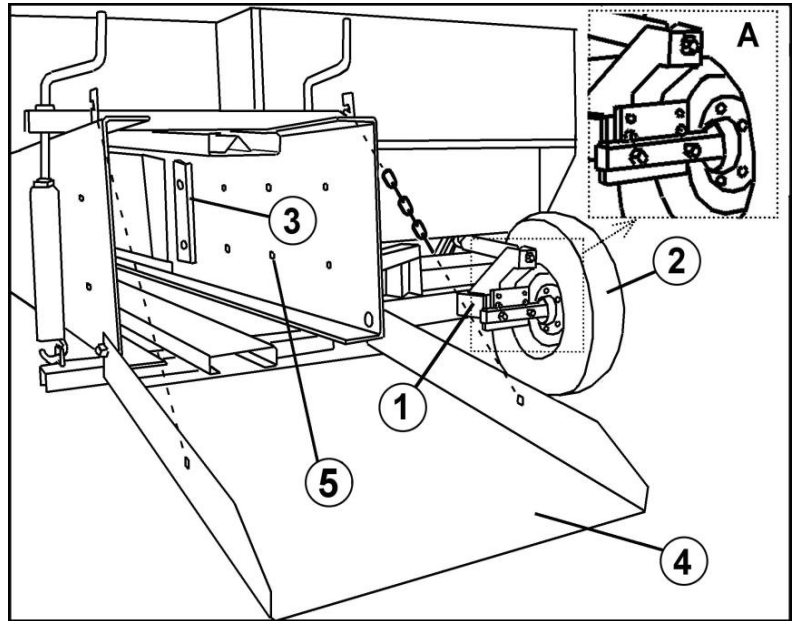

Fig. 25

THIRD WHEEL

The baler can be equipped with a third wheel (which has a reduced diameter), to be installed at the pick-up back, in order to protect it even or irregular ground (no. 1 Fig. 26).

The third wheel bracket (n°1 fig. 25) is the same as above, but the hub of the third wheel is fixed as shown in insert B or C of fig.26.

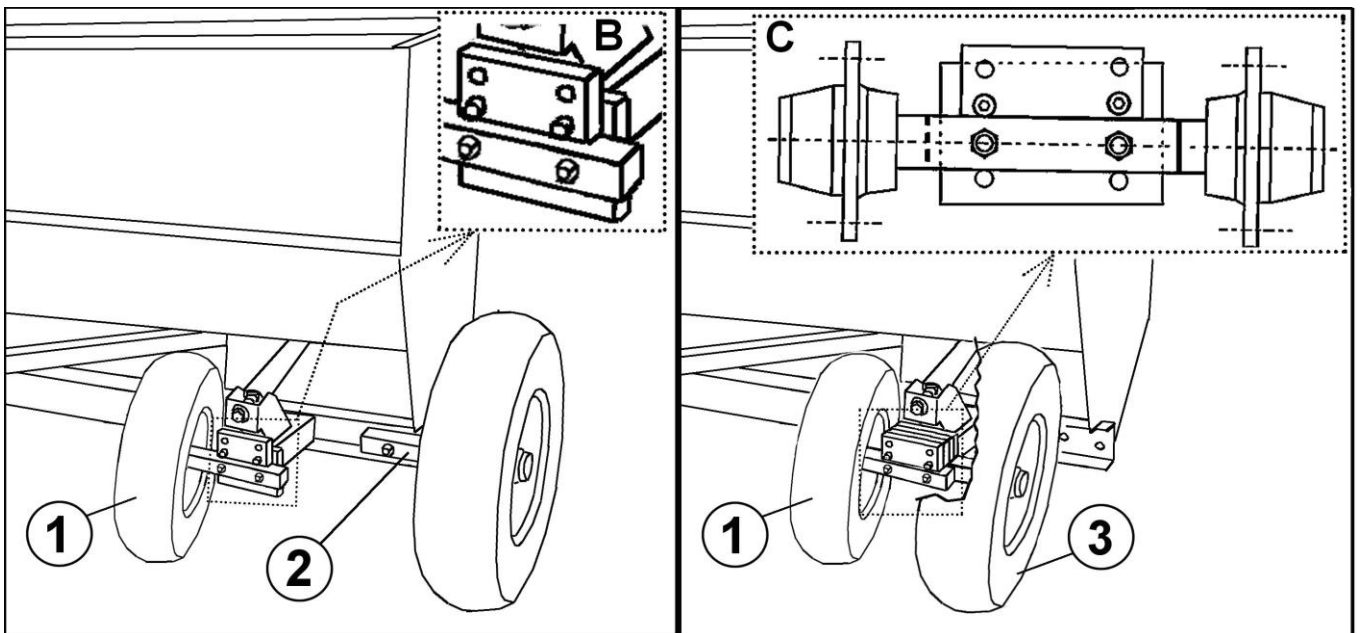

Fig.26

PICK-UP AND DRAWBAR HYDRAULIC CONTROL

The machine can be equipped with a hydraulic piston (no. 1 Fig. 27) to move the drawbar and a hydraulic lifting lever (no. 2 Fig. 27) to adjust the height of the pick-up.

These two movements can be activated through a hydraulic control lever located on the tractor.

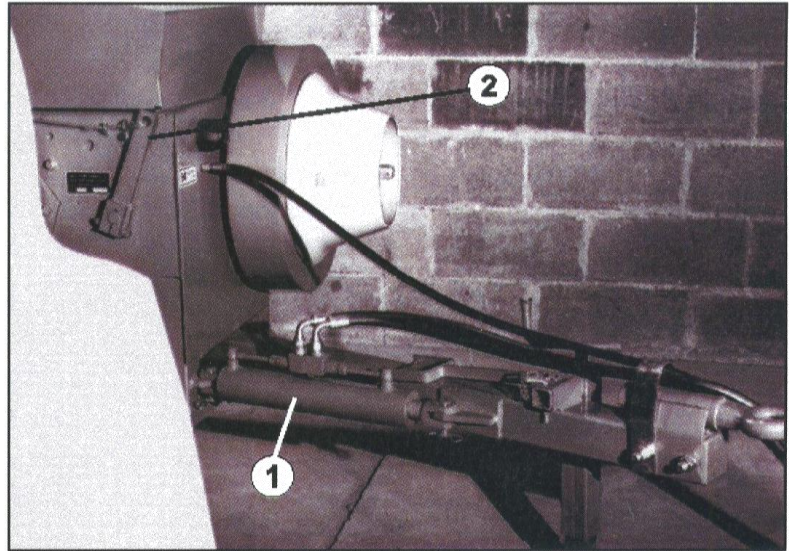

Fig. 27

CHARACTERISTICS

TECHNICAL DATA

		M61 EXPORT/160	M61 EXPORT/170
Bale tie		Twine or wire	Twine or wire
Bale chamber	cm	36x46	36x46
Straw bale weight	kg	16-28 about	16-28 about
Hay bale weight	kg	20-35 about	20-35 about
Bale length	cm	40-130	40-130
Capacity bales/minutes		4-10	4-10
Plunger strokes/minute		90	90
Tractor rating for P.T.O.	CV	26-30	26-30
Maximum width of the pick up	cm	160	170
Weight	kg	1150 / 1175	1250 / 1275
Overall width	cm	246	256
Overall width the side pick-up wheel mounted behind	cm	225	235
Length	cm	430	430
Height	cm	160	160
Tires		10.0/80-12 195/75-14 or 7.00-12	10.0/80-12 195/75-14 or 7.00-12

STANDARD EQUIPMENT

- Twine knotter
- Pick-up jack
- Bales counter
- Cardan shaft
- Third wheel support

SPECIAL EQUIPMENT

- Third wheel
- Third wheel with holder
- Hydraulic pick-up lift
- Hydraulic drawbar adj
- Long chute and rear trailer hitch
- Wide angle shaft
- Pick-up wheel
- Pick-up support roller
- Iron wire twister

END OF SEASON STORAGE

After eliminating all harvest residue, disconnecting the binding system and removing the twine, do the following:

- Thoroughly clean the interior and exterior of the machine. Dirt and humidity may create rust.
Important! Attention! Clean the machine by using a high pressure air unit. Don't use a high pressure water unit which could damage machine parts which cause the water to mix with the residual incrustations with their consequent solidification and hardening after cleaning.
- Loosen the V-belts.
- Inspect and disassemble moving parts, such as belt-tightening rollers, the cardan shaft, etc.; clean them and check again for wear. Replace them, if necessary, with new parts.
- Oil all parts of the cardan shaft.
- Thoroughly lubricate the machine.
- Clean the gears and change the oil.
- Replace worn or damaged tools.
- Touch-up damaged paint and spray a rust inhibitor on bare spots.
- Store the machine in a dry environment and inflate the tires.
- Make a list of all the spare parts required and order them ahead of time (for your seller it will be easier to prepare the spare parts during the off season). In this way your machine will be ready for use for the new season.

PREPARATION FOR THE NEW SEASON

- Lubricate the entire machine.
- Check the oil level. Top up, if necessary.
- Adjust all screws and nuts.
- Check all machine adjustments. Re-adjust, if necessary.
- Carefully re-read the use and maintenance handbook.



REMARK SHEET

A series of horizontal dotted lines spanning the width of the page, intended for handwritten notes.

ENGLISH